

EQUIPMENT SERVICES

2024 PRODUCT CATALOG

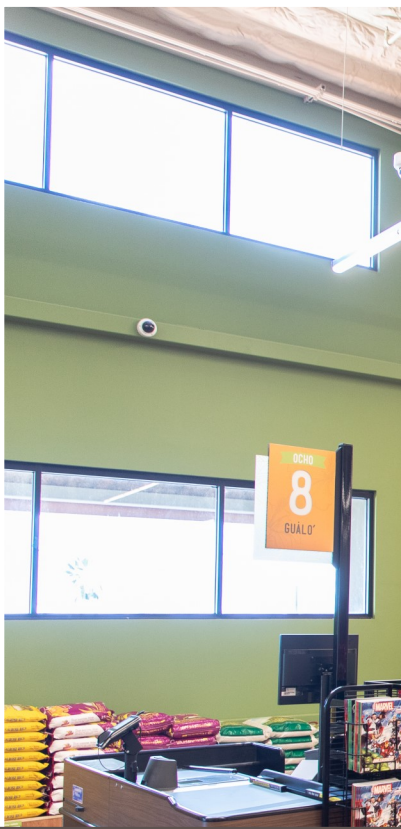



FRONT END

Equipment Services

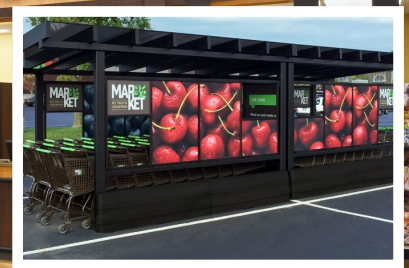

Inside this section:

Hand Baskets	5
Electric & Handicap Shopping Carts	7
2-Tier Shopping Carts	10
Kids Carts	17
Plastic Shopping Carts	19
Wire Shopping Carts	23
Cart Containment	34
Cart Corrals	35
Shopping Cart Accessories	39
Bike Racks & Benches	41
Checkout Counters	44
Checkout Accessories	46
Checkout Lights	48
Front End Merchandisers	49
Queue Lane Merchandisers	50
Self-Contained Merchandisers	51
Tobacco Merchandisers	52
Waste & Recycle Stations	54
Restrooms	56

**Contact UNFI Equipment Services for member pricing & ordering
equipmentservices@unfi.com or 1.800.835.0165**

Items in this catalog are subject to change & availability

Inside this section:

Front End Smallwares Program	57
Cash Handling	58
Breakroom	60
Office & Breakroom Furniture	62
Store Protection	63

Contact UNFI Equipment Services for member pricing & ordering
equipmentservices@unfi.com or 1.800.835.0165

Items in this catalog are subject to change & availability



GT26

- Ergonomic design
- Handle Colors: Blue, Red, Yellow, Green, Gray, Black

ITEM NO	SIZE	DESCRIPTION
GT26 LOGO	20"W X 10"H	BLACK BASKET W/COLORED HANDLE & LOGO
GT26 NO LOGO	20"W X 10"H	BLACK BASKET W/COLORED HANDLE NO LOGO
BSKSTANDMOB.BK	BASKET STAND	BLACK ROLLING BASKET STAND W/CASTERS
BSKSTAND.S.Z	BASKET STAND	ZINC PLATED, NO CASTERS



VERSACART NH

- Nylon handle
- Black, Dark Blue, Light Blue, Dark Green, Light Green, Red, Orange, Yellow, Light Grey & Tan

ITEM NO	SIZE	DESCRIPTION
206-28L NH 12	19.17"L X 13.27"W X 9.96"H	NYLON HANDLE 28L
206-28 RS		RACK & SIGN FOR 28L BASKET
201-599		RACK W/CASTERS FOR 28L BASKET



VERSACART WH

- Wire handle
- Black, Green, Blue, Red, Light Grey

ITEM NO	SIZE	DESCRIPTION
206-28L NH 12	19.17"L X 13.27"W X 9.96"H	WIRE HANDLE 28L
206-28 RS		RACK & SIGN FOR 28L BASKET
201-599		RACK W/CASTERS FOR 28L BASKET



GL-STD-LOGO

- Made from recycled plastic
- Red, Dark Blue, Med Blue, Yellow, Grape, Tan, Grey, Teal, Emerald, Orange, Plum, Black

ITEM NO	SIZE	DESCRIPTION
GL-STD-LOGO	17"L X 12"W X 9"H TOP 13.8"L X 8.8" BOTTOM	SETS OF 24 WITH RACK & SIGN



GL-LG-LOGO

- Made from recycled plastic
- Red, Dark Blue, Med Blue, Yellow, Grape, Tan, Grey, Teal, Emerald, Orange, Plum, Black

ITEM NO	SIZE	DESCRIPTION
GL-LG-LOGO	19.4"L X 13.3"W X 10"H TOP 15.5"L X 9.5"W BOTTOM	SETS OF 24 WITH RACK & SIGN



PEGGS HAND BASKET

- Heavy duty 1/4" galvanized chrome handle
- Red, Royal Blue, Forest Green, Black, Camel

ITEM NO	SIZE	DESCRIPTION
E241-RED	19.75"L X 13.5"W X 9.15"H	WIRE HANDLE
E242-RBLUE	19.75"L X 13.5"W X 9.15"H	WIRE HANDLE
E244-FGRN	19.75"L X 13.5"W X 9.15"H	WIRE HANDLE
E249-BLK	19.75"L X 13.5"W X 9.15"H	WIRE HANDLE
E252-CAMEL	19.75"L X 13.5"W X 9.15"H	WIRE HANDLE



RWR-SB-RB32L

- Ergonomic handles & 4 wheels
- Blue, Red, Green or Black

ITEM NO	SIZE	DESCRIPTION
RWR-SB-RB32L	22.83"L X 13.39"W X 14.17"H	32L, ROLLING, 2 HANDLES, 4 WHEELS



BARCELONA

- Ergonomic handles & 4 wheels
- Blue, Red, Green or Black

ITEM NO	SIZE	DESCRIPTION
BARCELONA	22.83" X 15.75"W X 17.32"H	54L, ROLLING, 2 HANDLES, 4 WHEELS



AMIGO VALUESHOPPER

- Front drive cart
- Anti-theft/collision avoidance options
- Available in blue, dark green, light green, silver, orange, red & yellow

ITEM NO	SIZE	DESCRIPTION
440300	VALUESHOPPER	FRONT DRIVE
44100	VALUSHOPPER 34	BEST FOR STORES OPEN 24 HOURS
440300-ST	VALUESHOPPER W/SMART TRACK	INCLUDES ANTI-THEFT TRACKING DEVICE
441000-ST	VALUSHOPPER 34 W/SMART TRACK	INCLUDES ANTI-THEFT TRACKING DEVICE
SS-AMIGO	COLLISION AVOIDANCE ADD-ON	DETECTS OBSTACLES, SLOWS OR STOPS CART
11480.2	BONUS AC CORD	STORES UNDER SEAT PEDESTAL OR COVER
12229.2	OUTLET COVER	KEEPS CORDS HEALTHY & WORKING



AMIGO SMARTSHOPPER

- Rear drive cart
- Anti-theft/collision avoidance options
- Available in silver or red

ITEM NO	SIZE	DESCRIPTION
420000	SMARTSHOPPER	MORE POWER FOR RAMPS & INCLINES
420000-ST	SMARTSHOPPER W/SMART TRACK	INCLUDES ANTI-THEFT DEVICE
SS-AMIGO	COLLISION AVOIDANCE ADD-ON	DETECTS OBSTACLES, SLOWS OR STOPS CART
11480.2	BONUS AC CORD	STORES UNDER SEAT PEDESTAL OR COVER
12229.2	OUTLET COVER	KEEPS CORDS HEALTHY & WORKING



AMIGO VISTA SHOPPER

- Rear drive motorized cart
- Available with a polymer or wire basket
- Available in red, blue, green or white

ITEM NO	SIZE	DESCRIPTION
VISTASHOPPER	56"L X 35"W X 37"H	24-VOLT 33AH AGM BATTERY; 500LB RIDER CAP.



MART CART MODEL 3563

- Zero degree turning radius
- Intelli-Charge system
- Available in red, green, blue, grey, yellow, black & orange

ITEM NO	SIZE	DESCRIPTION
280-3563	55"L X 25"W X 37"H	550LB RIDER CAPACITY & 200LB BASKET CAPACITY
200-1740	CORD REEL	OPTION ADD-ON
280-1374	XL BASKET	BASKET UPGRADE



MART CART ULTIMA

- Widest Seat available at 24"
- Rated at 1,000lb moving capacity
- Available in red, green, blue, grey, yellow, black & orange

ITEM NO	SIZE	DESCRIPTION
280-9563	55"L X 25"W X 37"H	800LB RIDER CAPACITY & 200LB BASKET CAPACITY
200-1740	CORD REEL	OPTION ADD-ON
280-1374	XL BASKET	BASKET UPGRADE



MART CART E-4

- Longer run times
- Intelligent LCD Display w/diagnostic module
- Available in burgundy, red, green, grey & black

ITEM NO	SIZE	DESCRIPTION
280-500	55.5"L X 24.5"W X 38.75"H	E4 MODEL, INTELLIGENT LCD DISPLAY & DIAGNOSTICS
200-1740	CORD REEL	OPTION ADD-ON
280-1374	XL BASKET	BASKET UPGRADE

**ELECTRIC & HANDICAP
CARTS**



AMIGO SMART CHAIR XT

- Assisted Shopping Chair
- Five-Point Harness
- For use with children to adults

ITEM NO	SIZE	DESCRIPTION
510000	29.25"W X 57.50"L X 42"H	450LB PASSENGER CAPACITY



AMIGO WHEELCHAIR

- Manual Shopping Chair
- Easy in and out of the seat
- For use with children to adults

ITEM NO	SIZE	DESCRIPTION
WHEELCHAIR20	29.25"W X 57.50"L X 42"H	450LB PASSENGER CAPACITY



MART CART CARE CHAIR

- Manual Shopping Chair
- Other basket options available
- Available in yellow or grey

ITEM NO	SIZE	DESCRIPTION
250-2100 FB	41"L X 28"W X 36.6"H	FRONT BASKET
250-2100 RFB	41"L X 28"W X 36.6"H	REAR & FRONT BASKET
250-2100 RB	41"L X 28"W X 36.6"H	REAR BASKET
250-2100 NB	41"L X 28"W X 36.6"H	NO BASKET



CAROLINE'S CART

- Increase Shopping Capacity
- Allows for eye contact with caregiver
- Available in black, gray, red, green & blue

ITEM NO	SIZE	DESCRIPTION
CC20.7Z.RED	6,000 CU IN BASKET CAPACITY	35-250 LB PASSENGER
CC20.7Z.BLACK	6,000 CU IN BASKET CAPACITY	35-250 LB PASSENGER
CC20.7Z.GREY	6,000 CU IN BASKET CAPACITY	35-250 LB PASSENGER
CC20.7Z.GREEN	6,000 CU IN BASKET CAPACITY	35-250 LB PASSENGER
CC20.7Z.BLUE	6,000 CU IN BASKET CAPACITY	35-250 LB PASSENGER

**ELECTRIC & HANDICAP
CARTS**



PEGG'S KNM799

- Use w/Firefly's special needs child seat
- Provides required trunk & head support
- Total shopping capacity 11,400 Cu. In.

ITEM NO	SIZE	DESCRIPTION
KNM799	BASKET CAPACITY 6,800 CU.IN.	BLACK METAL FRAME



5640 TECHNIBILT

- Total payload capacity 7,428 cu. in.
- 11-1/2" nesting distance
- Grey, black, red, blue or green plastic ac-

ITEM NO	SIZE	DESCRIPTION
5640-TECH	BLACK OR GRANITE METAL FRAME	CORNER BUMPERS ON TOP & BOTTOM BASKETS
TECH HANDLE SET UP FEE	ONE TIME SETUP LOGO FEE	BLOCK LETTERING
TECH HANDLE CUSTOM LOGO	ONE TIME SETUP LOGO FEE	CUSTOM LOGO
FRICWHEELINST	FRICTION WHEEL UPGRADE	SOLD IN PAIRS



5341 TECHNIBILT

- Total payload capacity 5,465 cu. in.
- 7-3/4" nesting distance
- Grey, black, red, blue or green plastic ac-

ITEM NO	SIZE	DESCRIPTION
5341SEAL	BLACK OR GRANITE METAL FRAME	CORNER BUMPERS ON TOP & BOTTOM BASKETS
TECH HANDLE SET UP FEE	ONE TIME SETUP LOGO FEE	BLOCK LETTERING
TECH HANDLE CUSTOM LOGO	ONE TIME SETUP LOGO FEE	CUSTOM LOGO
FRICWHEELINST	FRICTION WHEEL UPGRADE	SOLD IN PAIRS



5141D TECHNIBILT

- Total payload capacity 5,400 cu. in.
- 7-3/4" nesting distance
- Grey, black, red, blue or green plastic ac-

ITEM NO	SIZE	DESCRIPTION
5141SEAL	BLACK OR GRANITE METAL FRAME	CORNER BUMPERS ON TOP & BOTTOM BASKETS
TECH HANDLE SET UP FEE	ONE TIME SETUP LOGO FEE	BLOCK LETTERING
TECH HANDLE CUSTOM LOGO	ONE TIME SETUP LOGO FEE	CUSTOM LOGO
FRICWHEELINST	FRICTION WHEEL UPGRADE	SOLD IN PAIRS



UNARCO M-48

- Total capacity 4,247 cu. In.
- 8-1/4" nesting distance
- Black, grey, red, light blue, dark blue, or-

ITEM NO	SIZE	DESCRIPTION
M-48	BLACK OR GREY METAL FRAME	BLACK, GREY, RED, LIGHT BLUE, DARK BLUE, ORANGE, GREEN OR BEIGE ACCESSORIES
CNP:LOGO1	ONE TIME SETUP LOGO FEE	BLOCK LETTERING



VERSACART EXPRESS5050

- Total shopping capacity 8,680 cu. in.
- 7.28" nesting distance
- Black or metallic grey

ITEM NO	SIZE	DESCRIPTION
101-5050-B	31.69"L X 22.24"W X 40.14"H	REAR BASKET
CTM-400 SUF	ONE TIME SETUP LOGO FEE	CUSTOM LOGO, SINGLE COLOR BLACK, WHITE OR RED
CTM-400 H	ONE TIME SETUP LOGO FEE	CUSTOM LOGO PRINT FEE PER CART



VERSACART EXPRESS3500

- Total shopping capacity 11,915 cu. in.
- 6.81" nesting distance
- Black or metallic grey

ITEM NO	SIZE	DESCRIPTION
101-350-B	29.75"L X 21.77"W X 41.28"H	REAR BASKET
CTM-400 SUF	ONE TIME SETUP LOGO FEE	CUSTOM LOGO, SINGLE COLOR BLACK, WHITE OR RED
HLS	TUBE VIEW HANDLE LOGO	CUSTOM LOGO PRINT FEE PER CART



VERSACART EXPRESS3500 W/CHILD SEAT

- Total shopping capacity 11,915 cu. in.
- 6.81" nesting distance

ITEM NO	SIZE	DESCRIPTION
101-350-B-C	29.75"L X 21.77"W X 41.28"H	INCLUDES CHILD SEAT & REAR BASKET
CTM-400 SUF	ONE TIME SETUP LOGO FEE	CUSTOM LOGO, SINGLE COLOR BLACK, WHITE OR RED
HLS	TUBE VIEW HANDLE LOGO	CUSTOM LOGO PRINT FEE PER CART



VERSACART EXPRESS4545

- Total shopping capacity 6,628 cu. in.
- 7.48" nesting distance
- Metallic grey

ITEM NO	SIZE	DESCRIPTION
101-4545	27.56"L X 23.23"W X 39.76"H	PURSE HOOKS & CORNER BUMPERS
CTM-400 SUF	ONE TIME SETUP LOGO FEE	CUSTOM LOGO, SINGLE COLOR BLACK, WHITE OR RED
CTM-400 H	SNAP ON HANDLE LOGO	CUSTOM LOGO PRINT FEE PER CART



VERSACART EXPRESS4546

- Total shopping capacity 6,458 cu. in.
- 8.66" nesting distance
- Metallic grey

ITEM NO	SIZE	DESCRIPTION
101-4546-T	27.99"L X 23.62"W X 39.61"H	PURSE HOOKS & CORNER BUMPERS CUSTOM LOGO, SINGLE COLOR BLACK, WHITE OR RED
CTM-400 SUF	ONE TIME SETUP LOGO FEE	
CTM-400 H	SNAP ON HANDLE LOGO	CUSTOM LOGO PRINT FEE PER CART



VERSACART EXPRESS6000

- Total shopping capacity 9,000 cu. in.
- 6.5" nesting distance
- Black or metallic grey

ITEM NO	SIZE	DESCRIPTION
101-600-B	28.74"L X 21.77"W X 41.26"H	REAR BASKET CUSTOM LOGO, SINGLE COLOR BLACK, WHITE OR RED
CTM-400 SUF	ONE TIME SETUP LOGO FEE	
HLS	TUBE VIEW HANDLE LOGO	CUSTOM LOGO PRINT FEE PER CART



VERSACART EXPRESS6000 W/CHILD SEAT

- Total shopping capacity 9,000 cu. in.
- 6.5" nesting distance
- Black or metallic grey

ITEM NO	SIZE	DESCRIPTION
101-600-C	28.74"L X 21.77"W X 41.26"H	CHILD SEAT CUSTOM LOGO, SINGLE COLOR BLACK, WHITE OR RED
CTM-400 SUF	ONE TIME SETUP LOGO FEE	
HLS	TUBE VIEW HANDLE LOGO	CUSTOM LOGO PRINT FEE PER CART



VERSACART EXPRESS7030 W/CHILD SEAT

- Total shopping capacity 9,450 cu. in.
- 8.86" nesting distance
- Black

ITEM NO	SIZE	DESCRIPTION
101-7030-C-T	34.88"L X 23.03"W X 40.75"H	CHILD SEAT CUSTOM LOGO, SINGLE COLOR BLACK, WHITE OR RED
CTM-400 SUF	ONE TIME SETUP LOGO FEE	
CTM-400 H	SNAP ON HANDLE LOGO	CUSTOM LOGO PRINT FEE PER CART



VERSACART EXPRESS7050 W/CHILD SEAT

- Total shopping capacity 10,678 cu. in.
- 8.86" nesting distance
- Black or metallic grey

ITEM NO	SIZE	DESCRIPTION
101-7050-C-T	38.78"L X 23.03"W X 40.75"H	CHILD SEAT
CTM-400 SUF	ONE TIME SETUP LOGO FEE	CUSTOM LOGO, SINGLE COLOR BLACK, WHITE OR RED
CTM-400 H	SNAP ON HANDLE LOGO	CUSTOM LOGO PRINT FEE PER CART



VERSACART EXPRESS5150

- Total shopping capacity 9,273 cu. in.
- 7.28" nesting distance
- Black or metallic grey

ITEM NO	SIZE	DESCRIPTION
101-5150-B-T	32.7"L X 22.77"W X 40.9"H	REAR BASKET
CTM-400 SUF	ONE TIME SETUP LOGO FEE	CUSTOM LOGO, SINGLE COLOR BLACK, WHITE OR RED
CTM-400 H	SNAP ON HANDLE LOGO	CUSTOM LOGO PRINT FEE PER CART



VERSACART EXPRESS5150 W/CHILD SEAT

- Total shopping capacity 9,273 cu. in.
- 7.28" nesting distance
- Black or metallic grey

ITEM NO	SIZE	DESCRIPTION
101-5150-C-T	32.7"L X 22.77"W X 40.9"H	CHILD SEAT
CTM-400 SUF	ONE TIME SETUP LOGO FEE	CUSTOM LOGO, SINGLE COLOR BLACK, WHITE OR RED
CTM-400 H	SNAP ON HANDLE LOGO	CUSTOM LOGO PRINT FEE PER CART



VERSACART EXPRESS6150

- Total shopping capacity 8,555 cu. in.
- 6.69 nesting distance
- Black or metallic grey

ITEM NO	SIZE	DESCRIPTION
101-6150-B-T	31.50"L X 22.28"W X 41.06"H	REAR BASKET
CTM-400 SUF	ONE TIME SETUP LOGO FEE	CUSTOM LOGO, SINGLE COLOR BLACK, WHITE OR RED
CTM-400 H	SNAP ON HANDLE LOGO	CUSTOM LOGO PRINT FEE PER CART



VERSACART EXPRESS6150 W/CHILD SEAT

- Total shopping capacity 8,555 cu. in.
- 6.69 nesting distance
- Black or metallic grey

ITEM NO	SIZE	DESCRIPTION
101-6150-C-T	31.50"L X 22.28"W X 41.06"H	REAR BASKET
CTM-400 SUF	ONE TIME SETUP LOGO FEE	CUSTOM LOGO, SINGLE COLOR BLACK, WHITE OR RED
CTM-400 H	SNAP ON HANDLE LOGO	CUSTOM LOGO PRINT FEE PER CART



PEGG'S KNM085

- Total shopping capacity 5.060 cu. in.
- 8.5" nesting distance
- Black or grey

ITEM NO	SIZE	DESCRIPTION
KNM085	26"L X 20.75"W X 39.38"H	LOWER TRAY
PEGGS:LOGO	ONE TIME LOGO SETUP FEE	CUSTOM LOGO
PEGGS:SETUP	ONE TIME BLOCK LETTERING FEE	FOR QTY'S UNDER 25



PEGG'S KNM075

- Total shopping capacity 4,660 cu. in.
- 8.5" nesting distance
- Black or grey

ITEM NO	SIZE	DESCRIPTION
KNM075	25"L X 20"W X 39.5"H	CORNER BUMPERS
PEGGS:LOGO	ONE TIME LOGO SETUP FEE	CUSTOM LOGO
PEGGS:SETUP	ONE TIME BLOCK LETTERING FEE	FOR QTY'S UNDER 25



PEGG'S KNM076P

- Total shopping capacity 8,280 cu. In.
- 8.25" nesting distance
- Basket color options: red, royal blue, dark

ITEM NO	SIZE	DESCRIPTION
KNM076P	26"L X 18.5"W X 40.75"H	GREY METAL FRAME
PEGGS:LOGO	ONE TIME LOGO SETUP FEE	CUSTOM LOGO ON HANDLE & BASKET FRONT
PEGGS:SETUP	ONE TIME BLOCK LETTERING FEE	FOR QTY'S UNDER 25



PEGG'S KNM080

- Total shopping capacity 4,660 cu. In.
- 7.5" nesting distance
- Black or grey

ITEM NO	SIZE	DESCRIPTION
KNM080	25"L X 20"W X 39.5"H	CORNER BUMPERS
PEGGS:LOGO	ONE TIME LOGO SETUP FEE	CUSTOM LOGO ON HANDLE
PEGGS:SETUP	ONE TIME BLOCK LETTERING FEE	FOR QTY'S UNDER 25



RW ROGER'S WMP-TT073

- Total shopping capacity 5,508 cu. In.
- 8.66" nesting distance
- Black or grey

ITEM NO	SIZE	DESCRIPTION
WMP-TT703-GY	17.36"L X 20.98"W X 39.49"H	GREY FRAME W/GREY ACCESSORIES
WMP-TT703-BK	17.36"L X 20.98"W X 39.49"H	BLACK FRAME W/BLACK ACCESSORIES



INSTORE IS2

- Total shopping capacity 5,574 cu. In
- 6.50" nesting distance
- Black or grey

ITEM NO	SIZE	DESCRIPTION
IS2	37"H X 30.59"L X 21.33"W	GREY OR BLACK FRAME
TCM-CUPHOLDER	ADD-ON CUP HOLDER	FACTORY INSTALLED
TCM-SYSTEC HANDLE	UPGRADE SYSTEC ERGONOMIC HANDLE	ANTI-MICROBIAL, ANTI-STATIC



INSTORE E2

- Total shopping capacity 4,652 cu. In
- 7.28" nesting distance
- Grey with black accessories

ITEM NO	SIZE	DESCRIPTION
E2	22.44"W X 27.91"L X 40.35"H	GREY FRAME, BLACK ACCESSORIES
TCM-CUPHOLDER	ADD-ON CUP HOLDER	FACTORY INSTALLED
TCM-SYSTEC HANDLE	UPGRADE SYSTEC ERGONOMIC HANDLE	ANTI-MICROBIAL, ANTI-STATIC



INSTORE 2BB2

- Total shopping capacity 5,570 cu. In
- 8.86" nesting distance
- Grey with black accessories

ITEM NO	SIZE	DESCRIPTION
2BB2	39.5"H X 28.5"L X 24.02"W	GREY FRAME, BLACK ACCESSORIES
TCM-CUPHOLDER	ADD-ON CUP HOLDER	FACTORY INSTALLED
TCM-SYSTEC HANDLE	UPGRADE SYSTEC ERGONOMIC HANDLE	ANTI-MICROBIAL, ANTI-STATIC



INSTORE 3BB1

- Total shopping capacity 10,098 cu. In
- 11.22" nesting distance
- Grey with black accessories

ITEM NO	SIZE	DESCRIPTION
3BB1	42.05"L X 23.54"W X 36.22"H	GREY FRAME, BLACK ACCESSORIES
TCM-CUPHOLDER	ADD-ON CUP HOLDER	FACTORY INSTALLED
TCM-SYSTEC HANDLE	UPGRADE SYSTEC ERGONOMIC HANDLE	ANTI-MICROBIAL, ANTI-STATIC
TCM-SYSTEC BELT	UPGRADE SYSTEC SMARTSAFE SEATBELT	SELF-CLEANING, RETRACTABLE



INSTORE 5BB7

- Total shopping capacity 13,770 cu. In
- 11.42" nesting distance
- Grey with black accessories

ITEM NO	SIZE	DESCRIPTION
5BB7	48.27"L X 25.63"W X 42.48"H	GREY FRAME, BLACK ACCESSORIES
TCM-CUPHOLDER	ADD-ON CUP HOLDER	FACTORY INSTALLED
TCM-SYSTEC HANDLE	UPGRADE SYSTEC ERGONOMIC HANDLE	ANTI-MICROBIAL, ANTI-STATIC
TCM-SYSTEC BELT	UPGRADE SYSTEC SMARTSAFE SEATBELT	SELF-CLEANING, RETRACTABLE



TECHNIBILT 6825

- Total capacity 1,400 cu. in.
- Black handle reads "HAVE A NICE DAY" in white
- Finish options: black, red, grey or dayglo green

ITEM NO	SIZE	DESCRIPTION
6825-SEAL	23-1/2"L X 13-7/16"W X 25-7/8"H	4-1/2" NESTING DISTANCE
C-FLAG	CUSTOMER IN TRAINING FLAG	OPTIONAL



VERSACART 102-026

- 2,066 cu. In. capacity
- Custom handle option not available
- Red, or Metallic Grey available

ITEM NO	SIZE	DESCRIPTION
102-026	24.5"L X 13.78"W X 28.42"H	6.41" NESTING DISTANCE
900-026	ADD-ON FLAG & POLE	OPTIONAL



RTS RETAIL GO KARTS

- 12,750 cu. In. capacity
- Fits two children
- Police, Fire, Taxi, or Princess

ITEM NO	SIZE	DESCRIPTION
401400200A8000	52"L X 42"H X 27"W	POLICE CAR, 2-TIER CART
401400500A1000	52"L X 42"H X 27"W	TAXI, 2-TIER CART
401400300A0100	52"L X 42"H X 27"W	FIRE TRUCK, 2-TIER CART
401400400A0500	52"L X 42"H X 27"W	PRINCESS, 2-TIER CART



RTS SHUTTLE CART

- 12,750 cu. In. capacity
- Fits two children
- Green, Black, Red, Blue, Forest Green or Yellow

ITEM NO	SIZE	DESCRIPTION
4003-00100A-XX-00	52"L X 42"H X 27"W	SHUTTLE, 2-TIER CART



RTS TRACTOR CART

- 12,750 cu. In. capacity
- Fits two children
- Red, Orange, Forest Green or Black

ITEM NO	SIZE	DESCRIPTION
4016-00100A	53"L X 46"H X 27"W	TRACTOR, 2-TIER CART



TECHNIBILT RENAISSANCE

- Total payload capacity 18,120 cu. in.
- 10-1/2" nesting distance
- Black, grey, red, green or blue basket colors available

ITEM NO	SIZE	DESCRIPTION
HC-20-7Z-1	HANDLE READS THANK YOU	OPTIONAL LOGO ON BASKET FOR EASE OF NESTING & UN-NESTING CARTS
HC-20-CASTERLIFT	CASTER LIFTS	
HC-20-CUPHOLDER	OPTIONAL CUPHOLDER	INSTALLED ON NEW CARTS ONLY
HC-20-DIVIDER	PRODUCE/BREAD BASKET DIVIDER	INSTALLED ON FRONT OF CART
HC-20-LOGOPANEL	3 LOGO PANELS	ONE COLOR PRINT



UNARCO PC42U

- 40-13/16"l x 24-7/8"w x 42-3/16"h
- 13" nesting, 16,661 cu. In. capacity
- Granite grey metal frame, red, gray, black or blue plastic basket

ITEM NO	SIZE	DESCRIPTION
PC42U	OPTIONAL LOGO ON BASKET	INCLUDES P&H CASTERS
CNP:LOGO2	ONE TIME SETUP FEE FOR PLASTIC BASKET LOGO	



PEGGS KNM150

- Total shopping capacity 7,880 cu. in.
- 9.75" nesting distance
- Red, Royal Blue, Dark Blue, Dark Green, Grey, Black, Yellow, Orange, Beige

ITEM NO	SIZE	DESCRIPTION
KNM150	OPTIONAL LOGO ON HANDLE & BASKET	BASKET COLOR OPTIONS: RED, ROYAL BLUE, DARK BLUE, DARK GREEN, GREY, BLACK, YELLOW, ORANGE, OR BEIGE
PEGGS:LOGO	ONE TIME LOGO SETUP FEE	CUSTOM LOGO
PEGGS:SETUP	ONE TIME BLOCK LETTERING FEE	FOR QTY'S UNDER 25



PEGGS KNM530

- Total shopping capacity 11,100 cu. in.
- 10.75" nesting distance
- Red, Royal Blue, Dark Blue, Dark Green, Grey, Black, Yellow, Orange, Beige

ITEM NO	SIZE	DESCRIPTION
KNM530	OPTIONAL LOGO ON HANDLE & BASKET	BASKET COLOR OPTIONS: RED, ROYAL BLUE, DARK BLUE, DARK GREEN, GREY, BLACK, YELLOW, ORANGE, OR BEIGE
PEGGS:LOGO	ONE TIME LOGO SETUP FEE	CUSTOM LOGO
PEGGS:SETUP	ONE TIME BLOCK LETTERING FEE	FOR QTY'S UNDER 25



PEGGS KNM550

- Total shopping capacity 12,110 cu. in.
- 12.00" nesting distance
- Red, Royal Blue, Dark Blue, Dark Green, Grey, Black, Yellow, Orange, Beige

ITEM NO	SIZE	DESCRIPTION
KNM550	OPTIONAL LOGO ON HANDLE & BASKET	BASKET COLOR OPTIONS: RED, ROYAL BLUE, DARK BLUE, DARK GREEN, GREY, BLACK, YELLOW, ORANGE, OR BEIGE
PEGGS:LOGO	ONE TIME LOGO SETUP FEE	CUSTOM LOGO
PEGGS:SETUP	ONE TIME BLOCK LETTERING FEE	FOR QTY'S UNDER 25



PEGGS KNM600

- Total shopping capacity 13,505 cu. in.
- 13.5" nesting distance
- Red, Royal Blue, Dark Blue, Dark Green, Grey, Black, Yellow, Orange, Beige

ITEM NO	SIZE	DESCRIPTION
KNM600	OPTIONAL LOGO ON HANDLE & BASKET	BASKET COLOR OPTIONS: RED, ROYAL BLUE, DARK BLUE, DARK GREEN, GREY, BLACK, YELLOW, ORANGE, OR BEIGE
PEGGS:LOGO	ONE TIME LOGO SETUP FEE	CUSTOM LOGO
PEGGS:SETUP	ONE TIME BLOCK LETTERING FEE	FOR QTY'S UNDER 25



PEGGS KNM651

- Total shopping capacity 17,300 cu. in.
- 12" nesting distance
- Red, Royal Blue, Dark Blue, Dark Green, Grey, Black, Yellow, Orange, Beige

ITEM NO	SIZE	DESCRIPTION
KNM651	OPTIONAL LOGO ON HANDLE & BASKET	BASKET COLOR OPTIONS: RED, ROYAL BLUE, DARK BLUE, DARK GREEN, GREY, BLACK, YELLOW, ORANGE, OR BEIGE
PEGGS:LOGO	ONE TIME LOGO SETUP FEE	CUSTOM LOGO
PEGGS:SETUP	ONE TIME BLOCK LETTERING FEE	FOR QTY'S UNDER 25



PEGGS KNM655

- Total shopping capacity 10,300 cu. in.
- 12" nesting distance
- Red, Royal Blue, Dark Blue, Dark Green, Grey, Black, Yellow, Orange, Beige

ITEM NO	SIZE	DESCRIPTION
KNM655	OPTIONAL LOGO ON HANDLE & BASKET	BASKET COLOR OPTIONS: RED, ROYAL BLUE, DARK BLUE, DARK GREEN, GREY, BLACK, YELLOW, ORANGE, OR BEIGE
PEGGS:LOGO	ONE TIME LOGO SETUP FEE	CUSTOM LOGO
PEGGS:SETUP	ONE TIME BLOCK LETTERING FEE	FOR QTY'S UNDER 25



PEGGS KNM675

- Total shopping capacity 9,750 cu. in.
- 12" nesting distance
- Red, Royal Blue, Dark Blue, Dark Green, Grey, Black, Yellow, Orange, Beige

ITEM NO	SIZE	DESCRIPTION
KNM675	OPTIONAL LOGO ON HANDLE & BASKET	BASKET COLOR OPTIONS: RED, ROYAL BLUE, DARK BLUE, DARK GREEN, GREY, BLACK, YELLOW, ORANGE, OR BEIGE
PEGGS:LOGO	ONE TIME LOGO SETUP FEE	CUSTOM LOGO
PEGGS:SETUP	ONE TIME BLOCK LETTERING FEE	FOR QTY'S UNDER 25



RW ROGERS WMP-150L

- Total shopping capacity 12,730 cu. in.
- 10.24" nesting distance
- Blue, red or grey

ITEM NO	SIZE	DESCRIPTION
WMP-150L-BE	32.48"L x 21.46"W x 41.34"H	BLUE BASKET W/GREY FRAME
WMP-150L-RD	32.48"L x 21.46"W x 41.34"H	RED BASKET W/GREY FRAME
WMP-150L-GY	32.48"L x 21.46"W x 41.34"H	GREY BASKET W/GREY FRAME



RW ROGERS PLASTIC CART

- 11,575 cu. in. shopping capacity
- Black frame
- Choice of black, green, red, blue or grey accents

ITEM NO	SIZE	DESCRIPTION
EX-11575 RE BLK	24-3/4"W X 37"L X 40-3/4"H	BLACK BASKET W/BLACK ACCENTS
EX-11575 RE GRN	24-3/4"W X 37"L X 40-3/4"H	BLACK BASKET W/GREEN ACCENTS
EX-11575 RE RED	24-3/4"W X 37"L X 40-3/4"H	BLACK BASKET W/RED ACCENTS
EX-11575 RE BLUE	24-3/4"W X 37"L X 40-3/4"H	BLACK BASKET W/BLUE ACCENTS
EX-11575 RE GREY	24-3/4"W X 37"L X 40-3/4"H	BLACK BASKET W/GREY ACCENTS



VERSCART 103-072

- 10,747 cu. In. shopping capacity
- Metallic Grey Frame
- Choice of green, black, blue, light grey or red basket

ITEM NO	SIZE	DESCRIPTION
103-072	35.6"L X 21.1"W X 38.3"H	BLACK, BLUE, GREEN, LIGHT GREY OR RED BASKET W/GREY FRAME
LOGO FEES WILL APPLY		



VERSACART 103-145

- 15,557 cu, in, shopping capacity
- Metallic Grey Frame
- Choice of green, black, blue, light grey or red basket

ITEM NO	SIZE	DESCRIPTION
103-145	38.2"L X 21.7"W X 41.1"H	BLACK, BLUE, GREEN, LIGHT GREY OR RED BASKET W/GREY FRAME
LOGO FEES WILL APPLY		

VERSACART 103-172

- 16,340 cu. In. shopping capacity
- Metallic Grey Frame
- Choice of green, black, blue, light grey or red basket

ITEM NO	SIZE	DESCRIPTION
103-172	42.6"L X 23.8"W X 41.9"H	BLACK, BLUE, GREEN, LIGHT GREY OR RED BASKET W/GREY FRAME
LOGO FEES WILL APPLY		



UNARCO M90Z

- Describe the product, service, or event here. Include a brief description and any features.
- 11-5/8" nesting, 17,502 cu. In. capacity
- Granite grey frame, various plastic acces-

ITEM NO	SIZE	DESCRIPTION
M90Z	OPTIONAL LOGO ON HANDLE	FRAME COLOR: BLACK OR GREY ACCESSORY COLORS: RED, ORANGE, YELLOW, GREEN, DARK BLUE (280), BRIGHT BLUE (285), BLACK OR GREY
CNP-LOGO1	ONE TIME LOGO SETUP FEE	BLOCK LETTERING ON HANDLE



UNARCO M90ZX

- Describe the product, service, or event here. Include a brief description and any features.
- 11-5/8" nesting, 18,686 cu. In. capacity
- Granite grey frame, various plastic acces-

ITEM NO	SIZE	DESCRIPTION
M90ZX	OPTIONAL LOGO ON HANDLE	FRAME COLOR: BLACK OR GREY ACCESSORY COLORS: RED, ORANGE, YELLOW, GREEN, DARK BLUE (280), BRIGHT BLUE (285), BLACK OR GREY
CNP-LOGO1	ONE TIME LOGO SETUP FEE	BLOCK LETTERING ON HANDLE



UNARCO M100Z

- Describe the product, service, or event here. Include a brief description and any features.
- 11-5/8" nesting, 16,800 cu. In. capacity
- Granite grey frame, various plastic acces-

ITEM NO	SIZE	DESCRIPTION
M100Z	OPTIONAL LOGO ON HANDLE	FRAME COLOR: BLACK OR GREY ACCESSORY COLORS: RED, ORANGE, YELLOW, GREEN, DARK BLUE (280), BRIGHT BLUE (285), BLACK OR GREY
CNP-LOGO1	ONE TIME LOGO SETUP FEE	BLOCK LETTERING ON HANDLE



UNARCO M125Z

- Describe the product, service, or event here. Include a brief description and any features.
- 12-1/2" nesting, 17,000 cu. In. capacity
- Granite grey frame, various plastic acces-

ITEM NO	SIZE	DESCRIPTION
M125Z	OPTIONAL LOGO ON HANDLE	FRAME COLOR: BLACK OR GREY ACCESSORY COLORS: RED, ORANGE, YELLOW, GREEN, DARK BLUE (280), BRIGHT BLUE (285), BLACK OR GREY
CNP-LOGO1	ONE TIME LOGO SETUP FEE	BLOCK LETTERING ON HANDLE



1412 TECHNIBILT

- Describe the product, service, or event here. Include a brief description and any features.
- 12-1/4" nesting distance
- Grey, black or granite frame

ITEM NO	SIZE	DESCRIPTION
1412-TECH	37-29/32"L X 25-1/8"W X 40-3/16"H	ACCESSORY COLOR OPTIONS: GREY, BLACK, RED, BLUE OR GREEN
TECH HANDLE SET UP FEE	ONE TIME LOGO SETUP FEE	BLOCK LETTERING ON HANDLE
TECH HANDLE CUSTOM LOGO	ONE TIME LOGO SETUP FEE	CUSTOM SILK-SCREENED LOGO
FRICWHEELINST	FRICTION WHEEL	UPGRADE



3442 TECHNIBILT

- Describe the product, service, or event here. Include a brief description and any features.
- 12-3/8" nesting distance
- Grey, black or granite frame

ITEM NO	SIZE	DESCRIPTION
3442SEAL	42-5/16"L X 24"W X 41-3/4"H	ACCESSORY COLOR OPTIONS: GREY, BLACK, RED, BLUE OR GREEN
TECH HANDLE SET UP FEE	ONE TIME LOGO SETUP FEE	BLOCK LETTERING ON HANDLE
TECH HANDLE CUSTOM LOGO	ONE TIME LOGO SETUP FEE	CUSTOM SILK-SCREENED LOGO
FRICWHEELINST	FRICTION WHEEL	UPGRADE



3440 TECHNIBILT

- Describe the product, service, or event here. Include a brief description and any features.
- 12-3/8" nesting distance
- Grey, black or granite frame

ITEM NO	SIZE	DESCRIPTION
3440SEAL	42-1/16"L X 24"W X 39-1/2"H	ACCESSORY COLOR OPTIONS: GREY, BLACK, RED, BLUE OR GREEN
TECH HANDLE SET UP FEE	ONE TIME LOGO SETUP FEE	BLOCK LETTERING ON HANDLE
TECH HANDLE CUSTOM LOGO	ONE TIME LOGO SETUP FEE	CUSTOM SILK-SCREENED LOGO
FRICWHEELINST	FRICTION WHEEL	UPGRADE



4140 TECHNIBILT

- Describe the product, service, or event here. Include a brief description and any features.
- 12-1/2" nesting distance
- Grey, black or granite frame

ITEM NO	SIZE	DESCRIPTION
4140SEAL	37-5/16"L X 25-3/16"W X 39-5/16"H	ACCESSORY COLOR OPTIONS: GREY, BLACK, RED, BLUE OR GREEN
TECH HANDLE SET UP FEE	ONE TIME LOGO SETUP FEE	BLOCK LETTERING ON HANDLE
TECH HANDLE CUSTOM LOGO	ONE TIME LOGO SETUP FEE	CUSTOM SILK-SCREENED LOGO
FRICWHEELINST	FRICTION WHEEL	UPGRADE



6240 TECHNIBILT

- Describe the product, service, or event here. Include a brief description and any features.
- 12-1/8" nesting distance
- Grey, black or granite frame

ITEM NO	SIZE	DESCRIPTION
6240SEAL	38-5/16"L X 25-1/8"W X 39-15/16"H	ACCESSORY COLOR OPTIONS: GREY, BLACK, RED, BLUE OR GREEN
TECH HANDLE SET UP FEE	ONE TIME LOGO SETUP FEE	BLOCK LETTERING ON HANDLE
TECH HANDLE CUSTOM LOGO	ONE TIME LOGO SETUP FEE	CUSTOM SILK-SCREENED LOGO
FRICWHEELINST	FRICTION WHEEL	UPGRADE



6242 TECHNIBILT

- Describe the product, service, or event here. Include a brief description and any features.
- 12-3/4" nesting distance
- Grey, black or granite frame

ITEM NO	SIZE	DESCRIPTION
6242SEAL	38-3/32"L X 25-1/8"W X 42-13/32"H	ACCESSORY COLOR OPTIONS: GREY, BLACK, RED, BLUE OR GREEN
TECH HANDLE SET UP FEE	ONE TIME LOGO SETUP FEE	BLOCK LETTERING ON HANDLE
TECH HANDLE CUSTOM LOGO	ONE TIME LOGO SETUP FEE	CUSTOM SILK-SCREENED LOGO
FRICWHEELINST	FRICTION WHEEL	UPGRADE



6542 TECHNIBILT

- Describe the product, service, or event here. Include a brief description and any features.
- 13" nesting distance
- Grey, black or granite frame

ITEM NO	SIZE	DESCRIPTION
6542SEAL	43-3/4"L X 24"W X 41-7/8"H	ACCESSORY COLOR OPTIONS: GREY, BLACK, RED, BLUE OR GREEN
TECH HANDLE SET UP FEE	ONE TIME LOGO SETUP FEE	BLOCK LETTERING ON HANDLE
TECH HANDLE CUSTOM LOGO	ONE TIME LOGO SETUP FEE	CUSTOM SILK-SCREENED LOGO
FRICWHEELINST	FRICTION WHEEL	UPGRADE



6940 TECHNIBILT

- Describe the product, service, or event here. Include a brief description and any features.
- 12-1/2" nesting distance
- Grey, black or granite frame

ITEM NO	SIZE	DESCRIPTION
6940SEAL	45-3/16"L X 25-3/16"W X 40"H	ACCESSORY COLOR OPTIONS: GREY, BLACK, RED, BLUE OR GREEN
TECH HANDLE SET UP FEE	ONE TIME LOGO SETUP FEE	BLOCK LETTERING ON HANDLE
TECH HANDLE CUSTOM LOGO	ONE TIME LOGO SETUP FEE	CUSTOM SILK-SCREENED LOGO
FRICWHEELINST	FRICTION WHEEL	UPGRADE



1540 TECHNIBILT

- Describe the product, service, or event here. Include a brief description and any features.
- 10" nesting distance
- Grey, black or granite frame

ITEM NO	SIZE	DESCRIPTION
1540SEAL	35"L X 20-3/8"W X 40-1/8"H	ACCESSORY COLOR OPTIONS: GREY, BLACK, RED, BLUE OR GREEN
TECH HANDLE SET UP FEE	ONE TIME LOGO SETUP FEE	BLOCK LETTERING ON HANDLE
TECH HANDLE CUSTOM LOGO	ONE TIME LOGO SETUP FEE	CUSTOM SILK-SCREENED LOGO
FRICWHEELINST	FRICTION WHEEL	UPGRADE



2943 TECHNIBILT

- Describe the product, service, or event here. Include a brief description and any features.
- 10-3/16" nesting distance
- Grey, black or granite frame

ITEM NO	SIZE	DESCRIPTION
2943TECH	35-9/16"L X 21-11/32"W X 41"H	ACCESSORY COLOR OPTIONS: GREY, BLACK, RED, BLUE OR GREEN
TECH HANDLE SET UP FEE	ONE TIME LOGO SETUP FEE	BLOCK LETTERING ON HANDLE
TECH HANDLE CUSTOM LOGO	ONE TIME LOGO SETUP FEE	CUSTOM SILK-SCREENED LOGO
FRICWHEELINST	FRICTION WHEEL	UPGRADE



2638 TECHNIBILT

- Describe the product, service, or event here. Include a brief description and any features.
- 10-3/4" nesting distance
- Grey, black or granite frame

ITEM NO	SIZE	DESCRIPTION
2638SEAL	35-3/4"L X 21"W X 38-1/16"H	ACCESSORY COLOR OPTIONS: GREY, BLACK, RED, BLUE OR GREEN
TECH HANDLE SET UP FEE	ONE TIME LOGO SETUP FEE	BLOCK LETTERING ON HANDLE
TECH HANDLE CUSTOM LOGO	ONE TIME LOGO SETUP FEE	CUSTOM SILK-SCREENED LOGO
FRICWHEELINST	FRICTION WHEEL	UPGRADE



3241 TECHNIBILT

- Describe the product, service, or event here. Include a brief description and any features.
- 11" nesting distance
- Grey, black or granite frame

ITEM NO	SIZE	DESCRIPTION
3241	37-1/4"L X 22-1/2"W X 41-5/8"H	ACCESSORY COLOR OPTIONS: GREY, BLACK, RED, BLUE OR GREEN
TECH HANDLE SET UP FEE	ONE TIME LOGO SETUP FEE	BLOCK LETTERING ON HANDLE
TECH HANDLE CUSTOM LOGO	ONE TIME LOGO SETUP FEE	CUSTOM SILK-SCREENED LOGO
FRICWHEELINST	FRICTION WHEEL	UPGRADE



3340 TECHNIBILT

- Describe the product, service, or event here. Include a brief description and any features.
- 12" nesting distance
- Grey, black or granite frame

ITEM NO	SIZE	DESCRIPTION
3340SEAL	37-5/8"L X 25-1/4"W X 42-3/16"H	ACCESSORY COLOR OPTIONS: GREY, BLACK, RED, BLUE OR GREEN
TECH HANDLE SET UP FEE	ONE TIME LOGO SETUP FEE	BLOCK LETTERING ON HANDLE
TECH HANDLE CUSTOM LOGO	ONE TIME LOGO SETUP FEE	CUSTOM SILK-SCREENED LOGO
FRICWHEELINST	FRICTION WHEEL	UPGRADE



3342 TECHNIBILT

- Describe the product, service, or event here. Include a brief description and any features.
- 12-13/16" nesting distance
- Grey, black or granite frame

ITEM NO	SIZE	DESCRIPTION
3342TECH	37-5/8"L X 25-1/4"W X 42-3/16"H	ACCESSORY COLOR OPTIONS: GREY, BLACK, RED, BLUE OR GREEN
TECH HANDLE SET UP FEE	ONE TIME LOGO SETUP FEE	BLOCK LETTERING ON HANDLE
TECH HANDLE CUSTOM LOGO	ONE TIME LOGO SETUP FEE	CUSTOM SILK-SCREENED LOGO
FRICWHEELINST	FRICTION WHEEL	UPGRADE



3638 TECHNIBILT

- Describe the product, service, or event here. Include a brief description and any features.
- 12" nesting distance
- Grey, black or granite frame

ITEM NO	SIZE	DESCRIPTION
3638SEAL	37-1/4"L X 22-1/2"W X 39-1/2"H	ACCESSORY COLOR OPTIONS: GREY, BLACK, RED, BLUE OR GREEN
TECH HANDLE SET UP FEE	ONE TIME LOGO SETUP FEE	BLOCK LETTERING ON HANDLE
TECH HANDLE CUSTOM LOGO	ONE TIME LOGO SETUP FEE	CUSTOM SILK-SCREENED LOGO
FRICWHEELINST	FRICTION WHEEL	UPGRADE



6142 TECHNIBILT

- Describe the product, service, or event here. Include a brief description and any features.
- 12-1/8" nesting distance
- Grey, black or granite frame

ITEM NO	SIZE	DESCRIPTION
6142SEAL	39"L X 22-5/8"W X 40-11/16"H	ACCESSORY COLOR OPTIONS: GREY, BLACK, RED, BLUE OR GREEN
TECH HANDLE SET UP FEE	ONE TIME LOGO SETUP FEE	BLOCK LETTERING ON HANDLE
TECH HANDLE CUSTOM LOGO	ONE TIME LOGO SETUP FEE	CUSTOM SILK-SCREENED LOGO
FRICWHEELINST	FRICTION WHEEL	UPGRADE



1737 TECHNIBILT

- Describe the product, service, or event here. Include a brief description and any features.
- 8-7/16" nesting distance
- Grey, black or granite frame

ITEM NO	SIZE	DESCRIPTION
1737	30-3/8"L X 17-7/8"W X 34-3/8"H	ACCESSORY COLOR OPTIONS: GREY, BLACK, RED, BLUE OR GREEN
TECH HANDLE SET UP FEE	ONE TIME LOGO SETUP FEE	BLOCK LETTERING ON HANDLE
TECH HANDLE CUSTOM LOGO	ONE TIME LOGO SETUP FEE	CUSTOM SILK-SCREENED LOGO
FRICWHEELINST	FRICTION WHEEL	UPGRADE



1938 TECHNIBILT

- Describe the product, service, or event here. Include a brief description and any features.
- 9-1/8" nesting distance
- Grey, black or granite frame

ITEM NO	SIZE	DESCRIPTION
1938SEAL	31-5/8"L X 21-1/8"W X 37"H	ACCESSORY COLOR OPTIONS: GREY, BLACK, RED, BLUE OR GREEN
TECH HANDLE SET UP FEE	ONE TIME LOGO SETUP FEE	BLOCK LETTERING ON HANDLE
TECH HANDLE CUSTOM LOGO	ONE TIME LOGO SETUP FEE	CUSTOM SILK-SCREENED LOGO
FRICWHEELINST	FRICTION WHEEL	UPGRADE



VERSACART E SERIES 125L

- Describe the product, service, or event here. Include a brief description and any features.
- 7.9" nesting distance
- Grey frame with black accessories

ITEM NO	SIZE	DESCRIPTION
101-E125	37.95"L X 23.03"W X 40.75"H	CORNER BUMPERS & PURSE HOOK
HLS	LOGO FEE PER CART	FOR TUBE VIEW HANDLES
900-221 BLK	CUP HOLDER	E-SERIES CARTS ONLY



VERSACART E SERIES 160L

- Describe the product, service, or event here. Include a brief description and any features.
- 8.58" nesting distance
- Grey frame with black accessories

ITEM NO	SIZE	DESCRIPTION
101-E160	40.95"L X 23.23"W X 40.75"H	CORNER BUMPERS & PURSE HOOK
HLS	LOGO FEE PER CART	FOR TUBE VIEW HANDLES
900-221 BLK	CUP HOLDER	E-SERIES CARTS ONLY



VERSACART E SERIES 180L

- Describe the product, service, or event here. Include a brief description and any features.
- 10.894" nesting distance
- Grey frame with black accessories

ITEM NO	SIZE	DESCRIPTION
101-E180	42.52"L X 27.36"W X 41.34"H	CORNER BUMPERS & PURSE HOOK
HLS	LOGO FEE PER CART	FOR TUBE VIEW HANDLES
900-221 BLK	CUP HOLDER	E-SERIES CARTS ONLY



VERSACART E SERIES 85L

- Describe the product, service, or event here. Include a brief description and any features.
- 7.4" nesting distance
- Grey frame with black accessories

ITEM NO	SIZE	DESCRIPTION
101-E85-C	36.50"L X 22.56"W X 41.10"H	CORNER BUMPERS & PURSE HOOK
HLS	LOGO FEE PER CART	FOR TUBE VIEW HANDLES
900-221 BLK	CUP HOLDER	E-SERIES CARTS ONLY



VERSACART S SERIES 85L

- Describe the product, service, or event here. Include a brief description and any features.
- 8.46" nesting distance
- Grey frame with black accessories

ITEM NO	SIZE	DESCRIPTION
120-085	33.58"l x 18.35"w x 36.93"h	CORNER BUMPERS & PURSE HOOK
CTM-400 SUF	LOGO SETUP FEE	ONE-TIME CHARGE
CTM-400 H	LOGO FEE PER CART	FOR SNAP-ON HANDLES



VERSACART S SERIES 140L

- Describe the product, service, or event here. Include a brief description and any features.
- 9.06" nesting distance
- Grey frame with black accessories

ITEM NO	SIZE	DESCRIPTION
120-140	37.28"L X 21.46"W X 38.58"H	CORNER BUMPERS & PURSE HOOK
CTM-400 SUF	LOGO SETUP FEE	ONE-TIME CHARGE
CTM-400 H	LOGO FEE PER CART	FOR SNAP-ON HANDLES



VERSACART S SERIES 160L

- Describe the product, service, or event here. Include a brief description and any features.
- 9.06" nesting distance
- Grey frame with black accessories

ITEM NO	SIZE	DESCRIPTION
120-160	41.34"L X 22.44"W X 40.94"H	CORNER BUMPERS & PURSE HOOK
CTM-400 SUF	LOGO SETUP FEE	ONE-TIME CHARGE
CTM-400 H	LOGO FEE PER CART	FOR SNAP-ON HANDLES



VERSACART S SERIES 180L

- Describe the product, service, or event here. Include a brief description and any features.
- 10.83" nesting distance
- Grey frame with black accessories

ITEM NO	SIZE	DESCRIPTION
120-180	41.34"L X 22.44"W X 40.94"H	CORNER BUMPERS & PURSE HOOK
CTM-400 SUF	LOGO SETUP FEE	ONE-TIME CHARGE
CTM-400 H	LOGO FEE PER CART	FOR SNAP-ON HANDLES



VERSACART C SERIES 60L

- Describe the product, service, or event here. Include a brief description and any features.
- 9.05" nesting distance
- Black frame with black accessories

ITEM NO	SIZE	DESCRIPTION
101-C160-T	39.8"L X 23.5"W X 40.3"H	CORNER BUMPERS & PURSE HOOK
CTM-400 SUF	LOGO SETUP FEE	ONE-TIME CHARGE
CTM-400 H	LOGO FEE PER CART	FOR SNAP-ON HANDLES
900-222 BLK	CUP HOLDER	C-SERIES CARTS ONLY



PRECISION WIRE 766M

- Describe the product, service, or event here. Include a brief description and any features.
- 13-1/8" nesting distance
- Black, grey or granite frame

ITEM NO	SIZE	DESCRIPTION
766M	38.8"L X 25"W X 42.3"H	CELL & COUPON HOLDER



RW ROGERS WMP-90L-EC

- Describe the product, service, or event here. Include a brief description and any features.
- 8.27" nesting distance
- Grey e-coat finish with grey accessories

ITEM NO	SIZE	DESCRIPTION
WMP-90L-EC	26.73"L X 19.29"W X 36.54"H	SMALL STANDARD WIRE CART



RW ROGERS WMP-152L-EC

- Describe the product, service, or event here. Include a brief description and any features.
- 9.52" nesting distance
- Grey e-coat finish with grey accessories

ITEM NO	SIZE	DESCRIPTION
WMP-152L-EC	30.9"L X 21.06"W X 38.66"H	MEDIUM STANDARD WIRE CART



RW ROGERS WMP-180L-EC

- Describe the product, service, or event here. Include a brief description and any features.
- 11.8" nesting distance
- Grey e-coat finish with grey accessories

ITEM NO	SIZE	DESCRIPTION
WMP-180L-EC	33.31"L X 25.2"W X 40.08"H	LARGE STANDARD WIRE CART



INSTORE X2

- Describe the product, service, or event here. Include a brief description and any features.
- 9.10" nesting distance
- Grey e-coat finish with black accessories

ITEM NO	SIZE	DESCRIPTION
X2	40.15"L X 21.65"W X 38.77"H	GREY FRAME, BLACK ACCESSORIES
TCM-CUPHOLDER	ADD-ON CUP HOLDER	FACTORY INSTALLED
TCM-SYSTEC HANDLE	UPGRADE SYSTEC ERGONOMIC HANDLE	ANTI-MICROBIAL, ANTI-STATIC
TCM-SYSTEC BELT	UPGRADE SYSTEC SMARTSAFE SEATBELT	SELF-CLEANING, RETRACTABLE



INSTORE X4

- Describe the product, service, or event here. Include a brief description and any features.
- 10.55" nesting distance
- Grey e-coat finish with black accessories

ITEM NO	SIZE	DESCRIPTION
X4	41.25"L X 23.38"W X 40.78"H	GREY FRAME, BLACK ACCESSORIES
TCM-CUPHOLDER	ADD-ON CUP HOLDER	FACTORY INSTALLED
TCM-SYSTEC HANDLE	UPGRADE SYSTEC ERGONOMIC HANDLE	ANTI-MICROBIAL, ANTI-STATIC
TCM-SYSTEC BELT	UPGRADE SYSTEC SMARTSAFE SEATBELT	SELF-CLEANING, RETRACTABLE



INSTORE X5

- Describe the product, service, or event here. Include a brief description and any features.
- 11.00" nesting distance
- Grey e-coat finish with black accessories

ITEM NO	SIZE	DESCRIPTION
X5	37.83"L X 24.80"W X 42.12"H	GREY FRAME, BLACK ACCESSORIES
TCM-CUPHOLDER	ADD-ON CUP HOLDER	FACTORY INSTALLED
TCM-SYSTEC HANDLE	UPGRADE SYSTEC ERGONOMIC HANDLE	ANTI-MICROBIAL, ANTI-STATIC
TCM-SYSTEC BELT	UPGRADE SYSTEC SMARTSAFE SEATBELT	SELF-CLEANING, RETRACTABLE



INSTORE X8

- Describe the product, service, or event here. Include a brief description and any features.
- 10.63" nesting distance
- Grey e-coat finish with black accessories

ITEM NO	SIZE	DESCRIPTION
X8	44.53"L X 24.80"W X 40.39"H	GREY FRAME, BLACK ACCESSORIES
TCM-CUPHOLDER	ADD-ON CUP HOLDER	FACTORY INSTALLED
TCM-SYSTEC HANDLE	UPGRADE SYSTEC ERGONOMIC HANDLE	ANTI-MICROBIAL, ANTI-STATIC
TCM-SYSTEC BELT	UPGRADE SYSTEC SMARTSAFE SEATBELT	SELF-CLEANING, RETRACTABLE



INSTORE OX4

- Describe the product, service, or event here. Include a brief description and any features.
- 10.43" nesting distance
- Grey e-coat finish with black accessories

ITEM NO	SIZE	DESCRIPTION
OX4	44.33"L X 40"H X 24.17"W	GREY FRAME, BLACK ACCESSORIES
TCM-CUPHOLDER	ADD-ON CUP HOLDER	FACTORY INSTALLED
TCM-SYSTEC HANDLE	UPGRADE SYSTEC ERGONOMIC HANDLE	ANTI-MICROBIAL, ANTI-STATIC
TCM-SYSTEC BELT	UPGRADE SYSTEC SMARTSAFE SEATBELT	SELF-CLEANING, RETRACTABLE



INSTORE OX5

- Describe the product, service, or event here. Include a brief description and any features.
- 11.22" nesting distance
- Grey e-coat finish with black accessories

ITEM NO	SIZE	DESCRIPTION
OX5	44.29"L X 25.28"W X 42.24"H	GREY FRAME, BLACK ACCESSORIES
TCM-CUPHOLDER	ADD-ON CUP HOLDER	FACTORY INSTALLED
TCM-SYSTEC HANDLE	UPGRADE SYSTEC ERGONOMIC HANDLE	ANTI-MICROBIAL, ANTI-STATIC
TCM-SYSTEC BELT	UPGRADE SYSTEC SMARTSAFE SEATBELT	SELF-CLEANING, RETRACTABLE



INSTORE OX8

- Describe the product, service, or event here. Include a brief description and any features.
- 11.22" nesting distance
- Grey e-coat finish with black accessories

ITEM NO	SIZE	DESCRIPTION
OX8	44.17"L X 25.04"W X 42.4"H	GREY FRAME, BLACK ACCESSORIES
TCM-CUPHOLDER	ADD-ON CUP HOLDER	FACTORY INSTALLED
TCM-SYSTEC HANDLE	UPGRADE SYSTEC ERGONOMIC HANDLE	ANTI-MICROBIAL, ANTI-STATIC
TCM-SYSTEC BELT	UPGRADE SYSTEC SMARTSAFE SEATBELT	SELF-CLEANING, RETRACTABLE



INSTORE 1407

- Describe the product, service, or event here. Include a brief description and any features.
- 10.83" nesting distance
- Grey e-coat finish with black accessories

ITEM NO	SIZE	DESCRIPTION
1407	37.04"L X 21.53"W X 41.93"H	GREY FRAME, BLACK ACCESSORIES
TCM-CUPHOLDER	ADD-ON CUP HOLDER	FACTORY INSTALLED
TCM-SYSTEC HANDLE	UPGRADE SYSTEC ERGONOMIC HANDLE	ANTI-MICROBIAL, ANTI-STATIC
TCM-SYSTEC BELT	UPGRADE SYSTEC SMARTSAFE SEATBELT	SELF-CLEANING, RETRACTABLE



CART CONTAINMENT

HELPS PROTECT YOUR INVESTMENT

SPEND LESS ON MAINTENANCE , RETRIEVAL & FINES



Cart containment systems provide an effective solution that addresses the challenge of containing carts while preserving a user-friendly shopping experience. Gatekeeper's **CartControl & CartControl+** systems leverage innovative technology, the highest quality installations & highly-trained service professionals to deliver the most comprehensive cart containment system on the market.

- Replacement costs can decrease up to 90%
- Compliance with city ordinances & elimination of municipal retrieval fees & fines
- Increased sales from more available & better condition carts
- Stores can experience a full return on investment within a year of installation

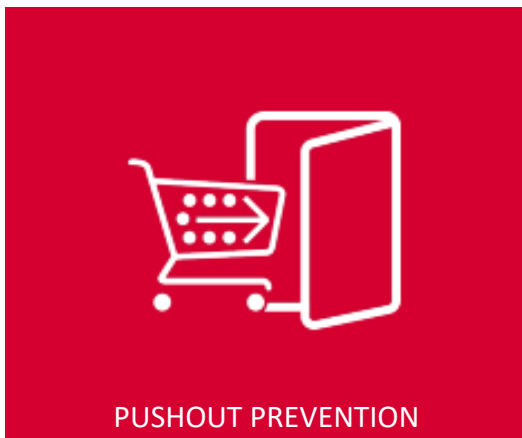

Push out theft stands at an estimated \$18 billion drain on the economy. Gatekeeper's automated **Purchek** pushout prevention system is your key to lowering shrink, increasing sales & improving safety at your stores.

- In-store anti-theft solution with an integrated locking wheel.
- Alarm sounds an instant before wheels lock alerting store personnel
- Confrontation free stops are the norm reducing opportunities for violence
- Uncover the real problem by gaining insight to the real scope & frequency of pushout theft

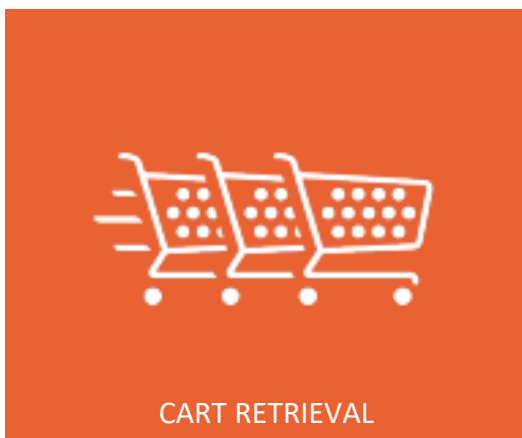

The **CartManager Ultra** is a cart retrieval unit that aids in reducing costs associated with manual cart retrieval including labor hours, injury liabilities & cart-vehicle accidents.

- Up to a 50% reduction in labor hours
- Clear lots faster
- More control over heavy cart loads
- Less injury claims

CONTACT UNFI EQUIPMENT SERVICES FOR MORE INFORMATION

EMAIL: EQUIPMENTSERVICES@UNFI.COM PHONE: 1.800.835.0165

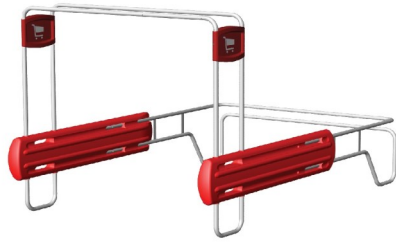

MCCUE CARTPARK BUMPER

- Molded side bumpers protect car doors
- Single, double & triple cart widths
- Available in red, blue, forest green or natural

ITEM NO	SIZE	DESCRIPTION
BP1	13'L X 3'-6"W X 3'-4"H (8'H SIGN)	SINGLE ENTRY, SINGLE CART WIDTH
BP2	13'L X 5'-11"W X 3'-4"H (8'H SIGN)	SINGLE ENTRY, DOUBLE CART WIDTH
BP3	13'L X 8'-4"W X 3'-4"H (8'H SIGN)	SINGLE ENTRY, TRIPLE CART WIDTH
BP2-BB		DOUBLE ENTRY, DOUBLE CART WIDTH
BP3-BB		DOUBLE ENTRY, TRIPLE CART WIDTH
BP2-LD-KIT	LANE DIVIDER KIT	FOR BP2 DOUBLE WIDTH COORALS
BP3-LD-KIT	LANE DIVIDER KIT	FOR BP3 TRIPLE WIDTH COORALS



MCCUE COVERED CARTPARK

- Includes molded side bumpers
- Single & double entry options
- Available in red, blue, forest green or natural

ITEM NO	SIZE	DESCRIPTION
SSC2B	8'-3"L X 8'-7"W X 8'-5"H	SINGLE ENTRY, 15 CART CAPACITY
SSC4B	14'-11"L X 8'-7"W X 8'-5"H	SINGLE ENTRY, 36 CART CAPACITY
SSC8B	28'-3"L X 8'-7"W X 8'-5"H	DOUBLE ENTRY, 72 CART CAPACITY
SSC10B	35'L X 8'-8"W X 8'-6"H	DOUBLE ENTRY, 83 CART CAPACITY
SSCC-SIDEPANEL-COMPLETE	SIDE WEATHER PANELS	INCLUDES HARDWARE
SSCC-ENDPANEL-COMPLETE	END WEATHER PANELS	INCLUDES HARDWARE



MCCUE CARTPARK ARCHITECTURAL OPEN

- For premium curb appeal & durability
- Includes standard sign
- Dark bronze anodized finish

ITEM NO	SIZE	DESCRIPTION
CPAS03	95"W X 98"H TO TOP OF SIGN X 164.25"L	SINGLE ENTRY, TRIPLE CART WIDTH INCLUDES SOLAR POWER KIT & STANDARD GRAPHICS
CPAS-LITPNL	LED BACKLIT SIGN OPTION	



MCCUE CARTPARK ARCHITECTURAL SHED ROOF

- For premium curb appeal & durability
- Sloped roof with exposed rafters
- Dark bronze anodized finish, optional graphic panels

ITEM NO	SIZE	DESCRIPTION
CPAS-4B-SR	11.45'L X 8'-8"W X 104.3" TO TOP OF ROOF	SINGLE ENTRY, TRIPLE CART WIDTH
CPAS-8B-SR	22'-11.8"L X 8'-8"W X 104.3" TO TOP OF ROOF	DOUBLE ENTRY, TRIPLE CART WIDTH
CPASC-SIDEPANEL-UPT	SIDE WEATHER PANELS	UV RESISTANT, DARK BRONZE FRAMES
CPASC-ENDPANEL-UPT	END PANEL	CLEAR PLASTIC
CPAS-ENDFRAME	END FRAME	ADD CUSTOM LOGO



MCCUE CARTPARK ARCHITECTURAL PEAKED ROOF

- For premium curb appeal & durability
- Designed to withstand heavy snow & winds
- Dark bronze anodized finish, optional

ITEM NO	SIZE	DESCRIPTION
CPAS-4B-UPT	164"L X 104"W X 107.05"H TO TOP OF ROOF	SINGLE ENTRY, TRIPLE CART WIDTH
CPAS-8B-B2B-UPT	330"L X 104"W X 107.05"H TO TOP OF ROOF	DOUBLE ENTRY, TRIPLE CART WIDTH
CPASA-LATTICE	OPTIONAL LATTICE	DARK BRONZE ANODIZED ALUMINUM
CPASC-SIDEPANEL-UPT	SIDE WEATHER PANELS	UV RESISTANT, DARK BRONZE FRAMES
CPASC-ENDPANEL-UPT	END PANEL	CLEAR PLASTIC
CPASC-ENDFRAME	END FRAME	ADD CUSTOM LOGO

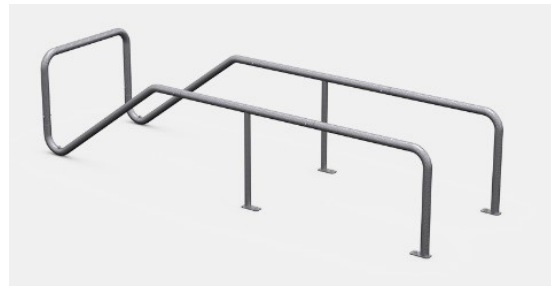

MCCUE CARTMAGNET SIDEWALK

- For stores w/limited outdoor/indoor space
- Single & double wide options
- Galvanized steel construction

ITEM NO	SIZE	DESCRIPTION
CMP1-SIDEWALKB	8'L X 2'-10"W, HOLDS 6 CARTS	SINGLE ENTRY, SINGLE WIDE
CMP2-SIDEWALKB	8'L X 5'-1"W, HOLDS 12 CARTS	SINGLE ENTRY, DOUBLE WIDE
CMC-SIDEWALK-EXTENDER-KIT	4' EXTENSION KIT	FOR SIDEWALK CORRALS



NATIONAL CART 603 SERIES

- Heavy-duty galvanized steel tubing
- Double wide, single or double entry
- Includes lane divider, standard sign available

ITEM NO	SIZE	DESCRIPTION
8030160	10'L X 5'W X 8'H	DOUBLE WIDE, SINGLE ENTRY
8030161	14'L X 5'W X 8'H	DOUBLE WIDE, SINGLE ENTRY
8030163	20'L X 5'W X 8'H	DOUBLE WIDE, DOUBLE ENTRY
8030164	28'L X 5'W X 8'H	DOUBLE WIDE, DOUBLE ENTRY

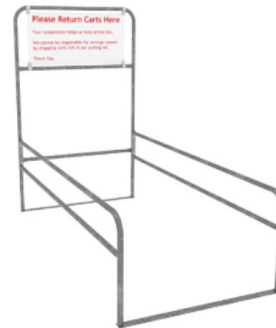

NATIONAL CART 602 SERIES

- Heavy-duty galvanized steel tubing
- Double wide, single or double entry
- Standard sign available

ITEM NO	SIZE	DESCRIPTION
8030154	10'L X 5'W X 8'H	DOUBLE WIDE, SINGLE ENTRY
8030157	20'L X 5'W X 8'H	DOUBLE WIDE, DOUBLE ENTRY



NATIONAL CART 361 SERIES

- Heavy-duty galvanized steel tubing
- Single wide, single or double entry
- Standard sign available

ITEM NO	SIZE	DESCRIPTION
8030136	10'L X 3'W X 8'H	SINGLE WIDE, SINGLE ENTRY
8030137	14'L X 3'W X 8'H	SINGLE WIDE, SINGLE ENTRY

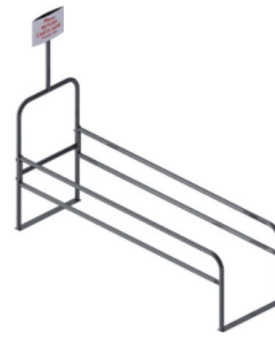

NATIONAL CART 360 SERIES

- Heavy-duty galvanized steel tubing
- Single wide, single or double entry
- Standard sign available

ITEM NO	SIZE	DESCRIPTION
8030130	10'L X 3'W X 8'H	SINGLE WIDE, SINGLE ENTRY
8030131	14'L X 3'W X 8'H	SINGLE WIDE, SINGLE ENTRY



NATIONAL CART 721 SERIES

- Heavy-duty galvanized steel tubing
- Double wide, single or double entry
- Includes lane divider, standard sign available

ITEM NO	SIZE	DESCRIPTION
8030172	10'L X 6'W X 8'H	DOUBLE WIDE, SINGLE ENTRY
8030173	14'L X 6'W X 8'H	DOUBLE WIDE, SINGLE ENTRY
8030175	20'L X 6'W X 8'H	DOUBLE WIDE, DOUBLE ENTRY
8030176	28'L X 6'W X 8'H	DOUBLE WIDE, DOUBLE ENTRY

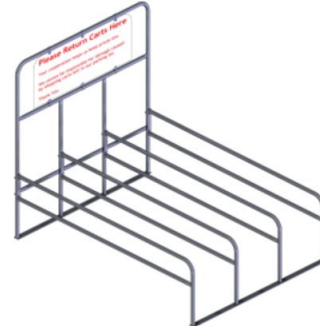

NATIONAL CART 901 SERIES

- Heavy-duty galvanized steel tubing
- Triple wide, single or double entry
- Includes lane dividers, standard sign available

ITEM NO	SIZE	DESCRIPTION
8030188	28'L X 7.5'W X 8'H	TRIPLE WIDE, DOUBLE ENTRY

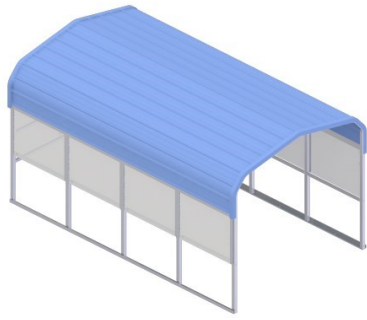

NATIONAL CART COVERED METAL

- Heavy-duty galvanized steel tubing
- Triple wide, single or double entry
- Standard & custom sign options available

ITEM NO	SIZE	DESCRIPTION
8030352	15'L X 8'-9"W X 8'H	TRIPLE WIDE, SINGLE ENTRY, RED ROOF

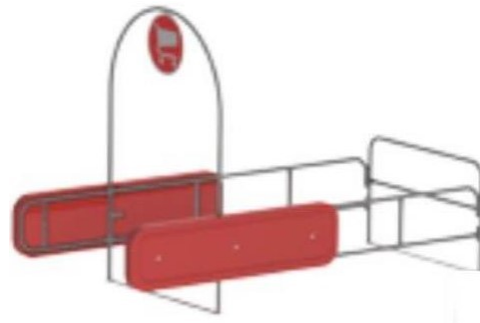

NATIONAL CART SNAP TOO BUMPER

- Heavy-duty galvanized steel tubing
- Arc style, three bay
- Blue, green, grey or red

ITEM NO	SIZE	DESCRIPTION
8030392	170"L X 101"W X 110"H	THREE BAY, SINGLE ENTRY



CART MANAGER ULTRA

- Remote & hand operated cart pusher
- High visibility light for safety awareness
- (2) 12v batteries with 104 Ahr capacity

ITEM NO	SIZE	DESCRIPTION
PA509710-R02	23.7"W X 55"H	LONGER MOTOR LIFESPAN



DANE QUICKART M3

- Remote & hand operated cart pusher
- Molded high impact Red ABS plastic
- Various battery options

ITEM NO	SIZE	DESCRIPTION
120-045	50"L X 27"W X 45"H	(3) 12v DEKA MAINTENANCE FREE BATTERIES (M3 HD)
120-044	50"L X 27"W X 45"H	(3) 12v EXIDENG-27 DEEP CYCLE BATTERIES (M3)



DANE QUICKART M4

- Remote & manual operation
- Molded high impact Red ABS plastic
- 30 cart capacity

ITEM NO	SIZE	DESCRIPTION
120.112	40.8"L X 27.2"W X 51.9"H	(3) 12v DEKA MAINTENANCE FREE BATTERIES (M3 HD)
100-507	REPLACEMENT REMOTE	2.4 GHz



AD FRAME

- Black plastic snap frame
- For use on cart fronts
- Weather resistant

ITEM NO	SIZE	DESCRIPTION
28878	HOLDS 8.3" X 11.7" SIGN INSERTS	DOUBLE SIDED

SHOPPING CART ACCESSORIES



SMARTSAFE SEAT BELT

- Automatically adjusts
- Various color options
- Plastic housing protects against rain & dirt

ITEM NO	SIZE	DESCRIPTION
53-40260-02	SYSTEC SEAT BELT	RED
53-40260-10	SYSTEC SEAT BELT	BLUE
53-40260-01	SYSTEC SEAT BELT	BLACK
53-40260-61	SYSTEC SEAT BELT	GREY



SMART PHONE HOLDER

- Adjusts to size of phone
- Mounts to almost all shopping carts
- 2 color options

ITEM NO	SIZE	DESCRIPTION
95-5200-6100-01-07	SYSTEC TECHNOLOGIES	GREY
95-5200-6100-01-02	SYSTEC TECHNOLOGIES	RED



ERGO XT HANDLE

- Ergonomic retrofit handle
- Fits most shopping cart handles
- Easy Installation

ITEM NO	SIZE	DESCRIPTION
53 40260 10	GREY FINISH	ANTI-STATIC FEATURE



MAX CR CART RETRIEVER

- Accommodates various cart sizes
- Strobe light for safety
- 2 battery options available

ITEM NO	SIZE	DESCRIPTION
MAX CR	55.75" L X 35.5" W X 47.75" H	105AH AGM BATTERY
MAX CR LB	55.75" L X 35.5" W X 47.75" H	60AH LITHIUM-ION BATTERY



DIAMOND PATTERN STEEL PARK BENCH

- 12" W diamond pattern bench seat and back
- Comes in a variety of different colors
- In-ground mounting options also available

ITEM NO	SIZE	DESCRIPTION
940SM-V6	72"L X 22"W X 35-3/16"H	SURFACE MOUNTED
940SM-V8	96"L X 22"W X 35-3/16"H	SURFACE MOUNTED
940SM-V10	120"L X 22"W X 35-3/16"H	SURFACE MOUNTED
940SM-V15	180"L X 22"W X 35-3/16"H	SURFACE MOUNTED



STEEL OUTDOOR FLAT BENCH

- UV stabilized , corrosion resistant powder -coating
- Black powder-coated finish
- Optional center arm accessory

ITEM NO	SIZE	DESCRIPTION
CBPB-6NB-BK	74"L X 20"W X 23.5"H	BLACK RIVER
CBPB-6NBA-BK	FITS W/ CBPB-6NB-BK	BLACK CENTER ARM



STEEL OUTDOOR BENCH W/ STRAIGHT BACK

- Solid texture powder-coated finish
- Black powder-coated finish
- Optional center arm accessory

ITEM NO	SIZE	DESCRIPTION
CBPB-6SB-BK	74"L X 24.25"W X 33"H	BLACK RIVER
CBPB-6WBA-BK	FITS W/ CBPB-6WBA-BK	BLACK CENTER ARM



RECYCLED PLASTIC PLANK BENCH

- Available with or without backrest
- Comes in a variety of different colors
- Custom engraved lettering optional

ITEM NO	SIZE	DESCRIPTION
PL4-P	48"L X 23-1/8"W X 31-3/4"H	INCLUDES BACKREST
PL6-P	72"L X 23-1/8"W X 31-3/4"H	INCLUDES BACKREST
PL8-P	84"L X 23-1/8"W X 31-3/4"H	INCLUDES BACKREST
PL4NB-P	48"L X 17"W X 18"H	BLACKLESS
PL6NB-P	72"L X 17"W X 18"H	BLACKLESS
PL8NB-P	84"L X 17"W X 18"H	BLACKLESS

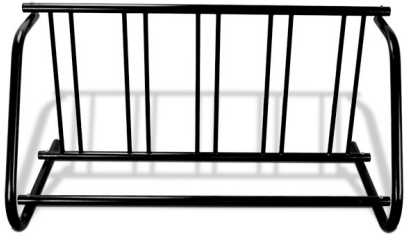

GRID BIKE RACK SINGLE SIDED

- Available in 4 and 5 bike spaces
- Silver metallic or black river powder-coated finish
- Anchor kit sold separately

ITEM NO	SIZE	DESCRIPTION
CBBR-4SG-SV	47-7/8"L X 30-7/8"W X 30-3/4"H	4 BIKE GRID, SILVER
CBBR-4SG-BK	47-7/8"L X 30-7/8"W X 30-3/4"H	4 BIKE GRID, BLACK
CBBR-5SG-SV	59-7/8"L X 30-7/8"W X 30-3/4"H	5 BIKE GRID, SILVER
CBBR-5SG-BK	59-7/8"L X 30-7/8"W X 30-3/4"H	5 BIKE GRID, BLACK
CBBR-GAK-SV	ANCHORING KIT	SILVER
CBBR-GAK-BK	ANCHORING KIT	BLACK

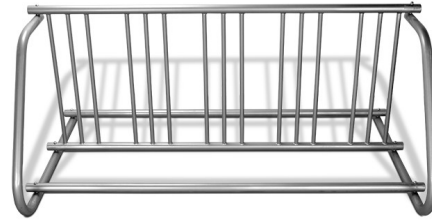

GRID BIKE RACK DOUBLE SIDED

- Available in 8 and 10 bike spaces
- Silver metallic powder-coated finish
- Anchor kit sold separately

ITEM NO	SIZE	DESCRIPTION
CBBR-8DG-SV	54-13/16"L X 39"W X 30-3/4"H	8 BIKE GRID, SILVER
CBBR-8DG-BK	54-13/16"L X 39"W X 30-3/4"H	8 BIKE GRID, BLACK
CBBR-10DG-SV	68-1/2"L X 39"W X 30-3/4"H	10 BIKE GRID, SILVER
CBBR-10DG-BK	68-1/2"L X 39"W X 30-3/4"H	10 BIKE GRID, BLACK
CBBR-GAK-SV	ANCHORING KIT	SILVER
CBBR-GAK-BK	ANCHORING KIT	BLACK

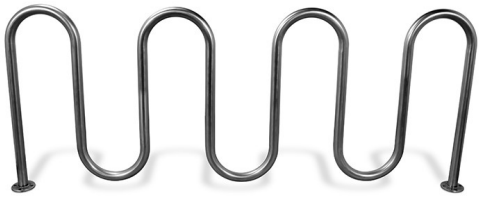

ROUND TUBE WAVE BIKE RACK

- 5, 7, and 9 bike capacity (3, 5 and 7 loops)
- Black powder-coated or stainless steel finish
- In-ground mounting options also available

ITEM NO	SIZE	DESCRIPTION
CBBR-5UR-BK	42-1/8"L X 36"H	3 LOOPS, SURFACE MOUNTED, BLACK
CBBR-5UR-SS	42-1/8"L X 36"H	3 LOOPS, SURFACE MOUNTED, STAINLESS STEEL
CBBR-7UR-BK	66-1/2"L X 36"H	5 LOOPS, SURFACE MOUNTED, BLACK
CBBR-7UR-SS	66-1/2"L X 36"H	5 LOOPS, SURFACE MOUNTED, STAINLESS STEEL
CBBR-9UR-BK	91"L X 36"H	7 LOOPS, SURFACE MOUNTED, BLACK
CBBR-9UR-SS	91"L X 36"H	7 LOOPS, SURFACE MOUNTED, STAINLESS STEEL



ROUND TUBE CIRCULAR BIKE RACK

- Offers two bike capacity
- Black powder-coated or stainless steel finish
- In-ground mounting options also available

ITEM NO	SIZE	DESCRIPTION
CBBR-2CR-BK	35"L X 31"H	SURFACE MOUNTED, BLACK
CBBR-2CR-SS	35"L X 31"H	SURFACE MOUNTED, STAINLESS STEEL



U' BIKE RACK

- Offers two bike capacity
- Black powder-coated or stainless steel finish
- In-ground mounting options also available

ITEM NO	SIZE	DESCRIPTION
CBBR-2UR-BK	22"W X 36"H	SURFACE MOUNTED, BLACK
CBBR-2UR-SS	22"W X 36"H	SURFACE MOUNTED, STAINLESS STEEL

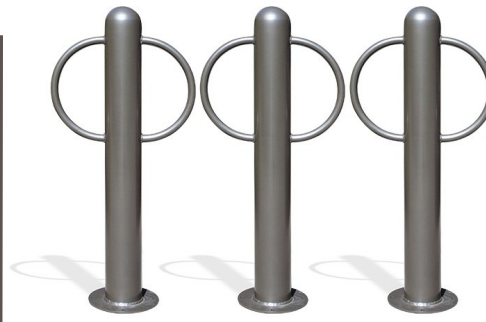

CLASSIC BIKE BOLLARD

- Premium powder-coating available
- Available in a variety of powder-coated finishes
- In-ground mounting options also available

ITEM NO	SIZE	DESCRIPTION
2633SM	6" DIAMETER, 3'H	SURFACE MOUNTED
2634SM	6" DIAMETER, 4'H	SURFACE MOUNTED
2833SM	8" DIAMETER, 3'H	SURFACE MOUNTED
2834SM	8" DIAMETER, 4'H	SURFACE MOUNTED

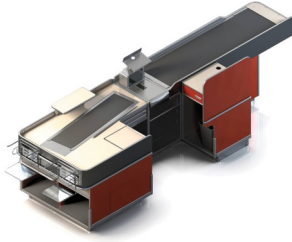

DUAL BELT CHECK STAND

- Belted takeaway
- Custom sizing, built to order
- Available in a variety of laminate finishes

ITEM NO	SIZE	DESCRIPTION
KCU 1500	CUSTOM TO STORE	LHTA
KCU 1500	CUSTOM TO STORE	RHTA
KCU 1500	CUSTOM TO STORE	H-STYLE

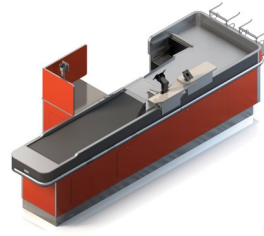

SINGLE BELT CHECK STAND

- Manual pass front belt system
- Custom sizing, built to order
- Available in a variety of laminate finishes

ITEM NO	SIZE	DESCRIPTION
KCU 3500	CUSTOM TO STORE	RHTA
KCU 3500	CUSTOM TO STORE	LHTA
KCU 3500	CUSTOM TO STORE	H-STYE

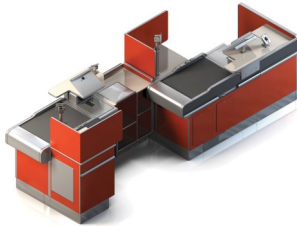

EXPRESS BELTED CHECK STAND

- Ideal for smaller footprints
- Custom sizing, built to order
- Available in a variety of laminate finishes

ITEM NO	SIZE	DESCRIPTION
KCU 5000 BLU	CUSTOM TO STORE	BELTED RHTA
KCU 5000 BLU	CUSTOM TO STORE	BELTED LHTA

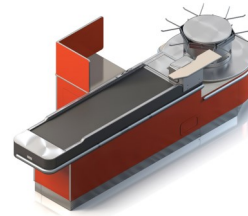

BELTED CAROUSEL

- Front belt System w/ Carousel style bagger
- Custom sizing, built to order
- Available in a variety of laminate finishes

ITEM NO	SIZE	DESCRIPTION
KCU 3500 CAROUSEL	CUSTOM TO STORE	BELTED W/ CAROUSEL BAGGING RHTA
KCU 3500 CAROUSEL	CUSTOM TO STORE	BELTED W/ CAROUSEL BAGGING LHTA



MOBILE CHECK STAND

- Beltless check out w/ castors for mobility
- Includes pull-out product staging shelf
- Available in a variety of laminate finishes

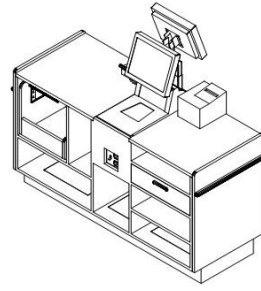

BANK LINE UP CHECK OUT COUNTERS

- Beltless banked registers
- Custom sizing, built to order
- Available in a variety of laminate finishes

ITEM NO	SIZE	DESCRIPTION
KCU 5000 Mobile	66"L x 28"W	NO BATTERY SYSTEM

ITEM NO	SIZE	DESCRIPTION
KCU 5000 BLU	CUSTOM TO STORE	BELTELESS RHTA
KCU 5000 BLU	CUSTOM TO STORE	BELTELESS LHTA

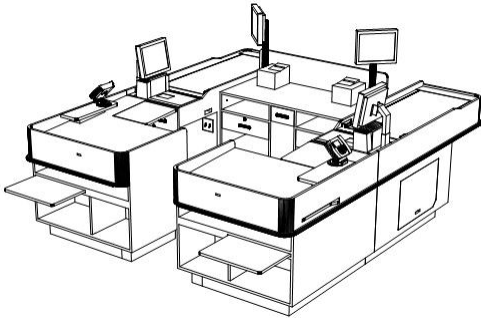

H-STYLE CHECK LANES

- Front belt scan & bag
- Merchandising options available
- Custom size and laminate finishes

ITEM NO	SIZE	DESCRIPTION
KCU 3500 HYBRID	CUSTOM TO STORE	H-CONFIGURATION
KCU 3500 HYBRID	CUSTOM TO STORE	H-CONFIGURATION W/ DRY MERCHANDISER
KCU 3500 HYBRID	CUSTOM TO STORE	H-CONFIGURATION W/ MERCHANDISER COOLER



TOP MOUNT BASE

- Adjustable
- Used on 21"W belted checkstands

ITEM NO	SIZE	DESCRIPTION
22-M101BW	14"-24-1/2"H 2" I.D BASE, 2" x 4-1/2" FOOT	USED W/ 22-S0781B POST
22-S0782BW	5" - 15-3/4"H, 2" I.D BASE, 2" X 4-1/2" FOOT	USED W/ 22-S0781B POST



STANDARD POST

- Uses 60-0310 Upper T-knob
- Held by bases using 60-0309 Lower T-knob

ITEM NO	SIZE	DESCRIPTION
22-S0781BW	14" T, 2" O.D. BASE	USED W/ 22-M101 & 22-S0782 BASES

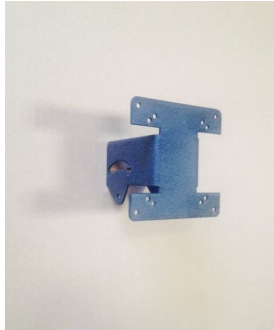

KEYBOARD DISPLAY BRACKET

- Applications differ

ITEM NO	SIZE	DESCRIPTION
22-M117BW	VESA MOUNT 75MM & 100MM HOLD PATTERNS	USED ON TOUCH SCREEN APPLICATIONS
22-M114	VESA MOUNT 75 MM HOLD PATTERN ONLY	USED ON TOUCH SCREEN NCR DYNAKEY KEYBOARDS

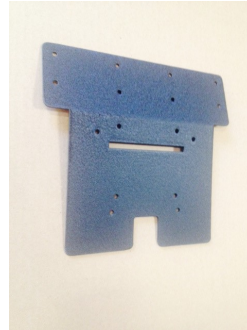

KEYBOARD DISPLAY PLATTER

- Applications differ

ITEM NO	SIZE	DESCRIPTION
22-P301B	9-1/4" X 8-3/4"	USED W/ 22-20783 BRACKET
22-0004BW	13-1/4"W x 9-7/8" T w/ 1-1/8" RETURN	USED W/ 22-20783 BRACKET
22-0011	15-1/4"W X 6-15/16" T W/ 3/4" RETURN	USED W/ 22-20783 BRACKET

PROTECTIVE SHIELD

- Checkstand and Customer Service Applications
- Attached easily to existing equipment
- Added as an upgrade to checkstand or sold separately

ITEM NO	SIZE	DESCRIPTION
PROTECTIVE SHIELD	STANDARD SIZE 31" X 36"	CUSTOM SIZED BY REQUEST



BAG RACK

- Corner and Closed Arm Styles
- Available in black
-

ITEM NO	SIZE	DESCRIPTION
46951-6	9.25"	BLACK COLOR ONLY
108188	CORNER BAG RACK	BLACK COLOR ONLY



ANTIMICROBIAL BELT

- Upgraded on new checkstands or can replace existing
- Antimicrobial property to reduce manual cleaning
- Cleaning system available for daily use

ITEM NO	SIZE	DESCRIPTION
MOLCHEM	CUSTOM TO ORDER	ANTIMICROBIAL BELT
MOLCHEM CLEANER	CLEANING SET	CLEANER FOR ANTIMICROBIAL BELT

CHECK OUT LIGHTS

STOCK & CUSTOM OPTIONS AVAILABLE
ENHANCE THE CHECKOUT EXPERIENCE

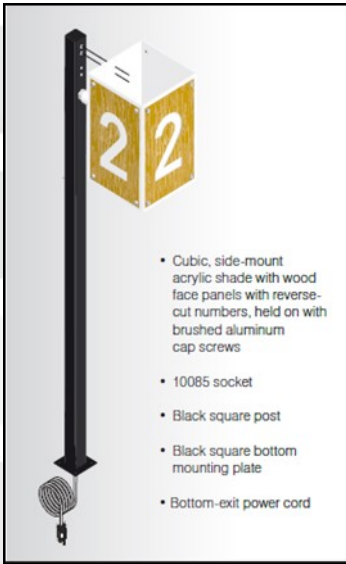

SVU-#2

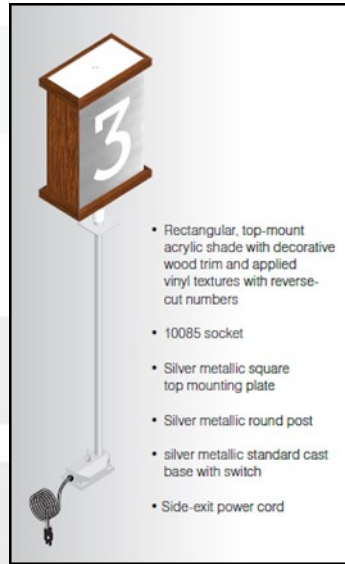

SVU-#3

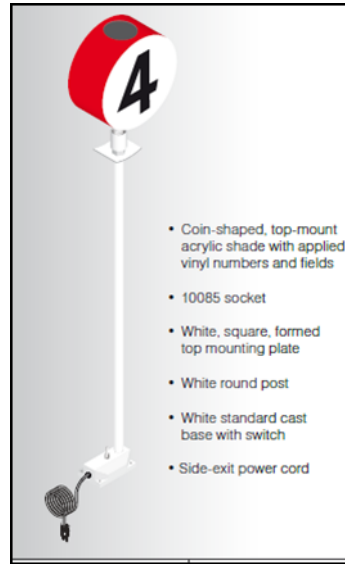

SVU-#4

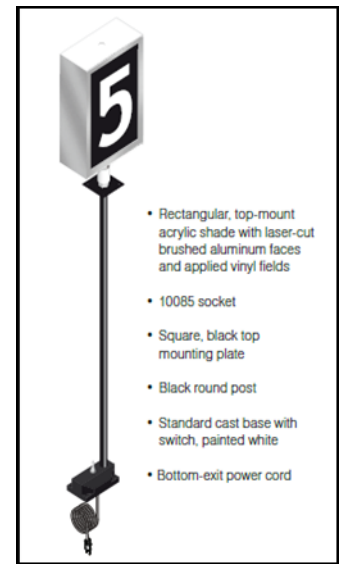

SVU-#5

Choose your design and customize colors to fit your existing interior or contact us for a custom solution

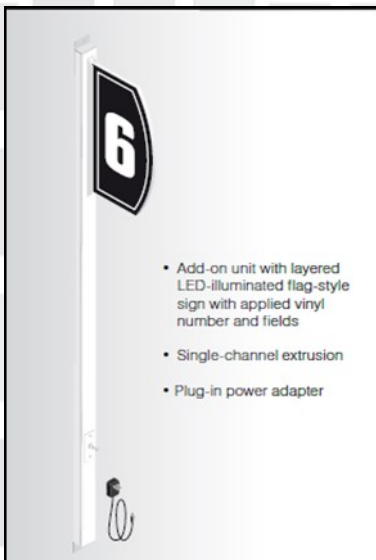

SVU-#6



SVU-#7

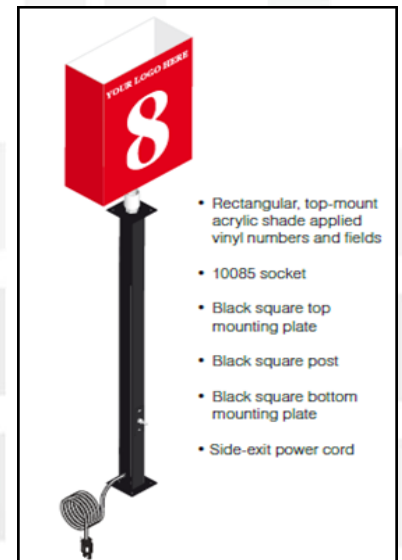

SVU-#8

Front End Merchandisers

With UNFI you have 2 options for Front End Merchandisers

1. Sign up for the UNFI Wholesale Front End Program and receive free fixtures, annual rebates and more. A contract is required.

Contact your UNFI Sales Rep for more information

2. For customers who choose not to participate in the UNFI Wholesale Front End Program, Equipment Services offers custom Front End Merchandisers for purchase to fit your stores unique needs.

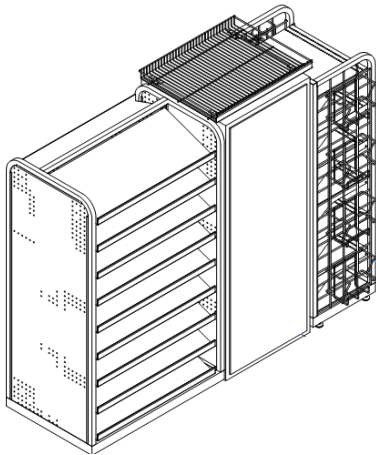

We offer displays to fit any scenario....

- Standard Checklanes
- H-Lanes
- Lane Blockers
- Lanes with soda coolers
- Toppers & wings for soda coolers
- Solid & wire shelves
- Pegged sections, magazine pockets

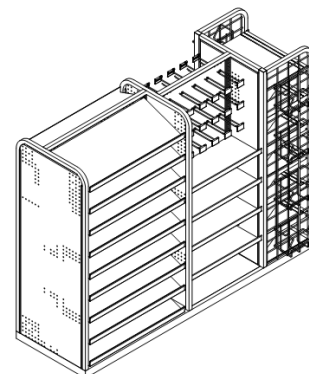
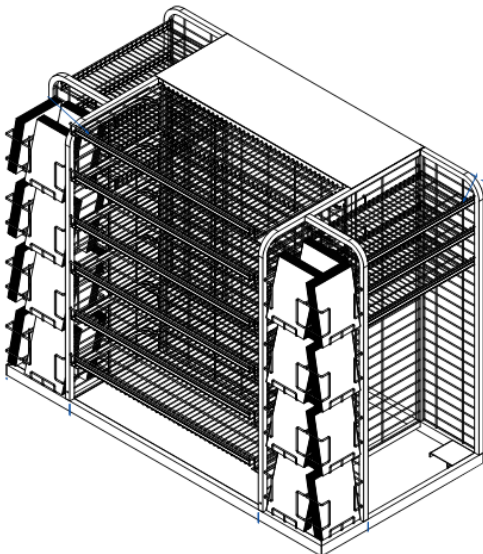

Contact UNFI Equipment Services for more information

Queue Lane Merchandisers

With UNFI you also have 2 options for Queue Lane Merchandisers

1. Sign up for the UNFI Wholesale Front End Program and receive free fixtures, annual rebates and more. A contract is required.

Contact your UNFI Sales Rep for more information

2. For customers who choose not to participate in the UNFI Wholesale Front End Program, Equipment Services offers custom Queue Lane Merchandisers for purchase to fit your stores unique needs.



Contact UNFI Equipment Services for more information



REFRIGERATED MERCHANDISER

- Self-Contained R290 Refrigerant
- System holds 33°F to 38°F
- Available in white, black and stainless steel

ITEM NO	SIZE	DESCRIPTION
GDM-06-34-HC-TSL01-EXT TOP	20-3/4"W x 26-3/8"D x 33-5/8"H	REFRIGERATED SWING DOOR COUNTER-TOP MERCHANDISER, 1 DOOR
GDM-10-HC-TSL01	24-7/8"W x 22-7/8"D x 53-3/8"H	REFRIGERATED SWING DOOR GLASS MERCHANDISER, 1 DOOR
GDM-10PT-HC-TSL01	24-7/8"W x 25-1/2"D x 53-3/8"H	REFRIGERATED SWING DOOR PASS-THRU GLASS MERCHANDISER, 1 DOOR
GDM-49-HC-TSL01	54-1/8" x 29-3/4" x 78-5/8"H	REFRIGERATED SWING DOOR GLASS MERCHANDISER, 2 DOORS
GDM-72-HC-TSL01	78-1/8"W x 29-7/8" x 78-5/8"H	REFRIGERATED SWING DOOR GLASS MERCHANDISER, 3 DOORS



FREEZER MERCHANDISER

- Self-Contained R290 Refrigerant
- Maintains -10°F, ideal for ice cream
- Available in white, black and stainless steel

ITEM NO	SIZE	DESCRIPTION
GDM-10F-HC-TSL01	24-7/8"W x 22-7/8"D x 53-3/8"H	FROZEN SWING DOOR GLASS MERCHANDISER, 1 DOOR
GDM-49-HC-TSL01	54-1/8" x 29-3/4" x 78-5/8"H	FROZEN SWING DOOR GLASS MERCHANDISER, 2 DOORS
GDM-72-HC-TSL01	78-1/8"W x 29-7/8" x 78-5/8"H	FROZEN SWING DOOR GLASS MERCHANDISER, 3 DOORS

SELF-CONTAINED MERCHANDISERS



OPEN AIR MERCHANDISER

- Glass sides available
- No Sign option available
- Perfect for end cap merchandising

ITEM NO	SIZE	DESCRIPTION
TOAM-48-HC-TSL01	48"W x 29-7/8" x 78-1/2"H	REFRIGERATED OPEN AIR MERCHANDISER



ICE MERCHANDISER

- Glass door
- Maintains 20°F to 25°F
- LED Lighting

ITEM NO	SIZE	DESCRIPTION
GDIM-49NT-HC-TSL01	54-1/8" x 29-7/8" x 78 5/8"	SWING DOOR NO TANK FREEZER WITH HYDROCARBON REFRIGERANT
GDIM-26NT-HC-TSL01	30"W x 29-7/8" x 78-5/8"	SWING DOOR NO TANK FREEZER WITH HYDROCARBON REFRIGERANT

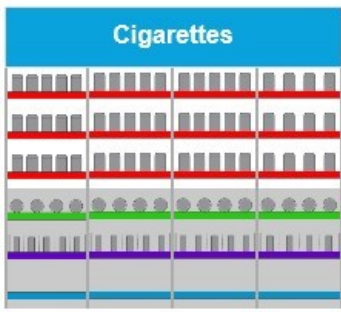

4FT LOW PROFILE TOBACCO RACKS

- Can be used on floor or counter
- Ships assembled, storage behind header
- Incl pushers for single packs, smokeless, vape and flat shelves for cartons

ITEM NO	SIZE	DESCRIPTION
TOB-4FT LP BK	4'W X 55"H X 16"D	BLACK FINISH
TOB-4FT LP SM	4'W X 55"H X 16"D	SILVER FINISH

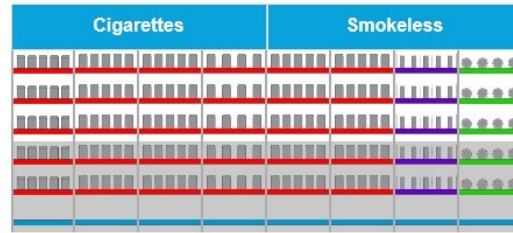

8FT LOW PROFILE TOBACCO RACKS

- Can be used on floor or counter
- Ships assembled, storage behind header
- Incl pushers for single packs, smokeless, vape and flat shelves for cartons

ITEM NO	SIZE	DESCRIPTION
TOB-8FT LP BK	8'W X 55"H X 16"D	BLACK FINISH
TOB-8FT LP SM	8'W X 55"H X 16"D	SILVER FINISH



4FT LOW PROFILE SECURITY DOORS

- Swing-out doors
- Clear plexi insert w/ aluminum frame
- Handles include hole for lock (lock not included)

ITEM NO	SIZE	DESCRIPTION
TOB-4LSD- 291364-R1	4'W X 55"H	BLACK FINISH
TOB-4LSD- 291365-R1	4'W X 55"H	SILVER FINISH

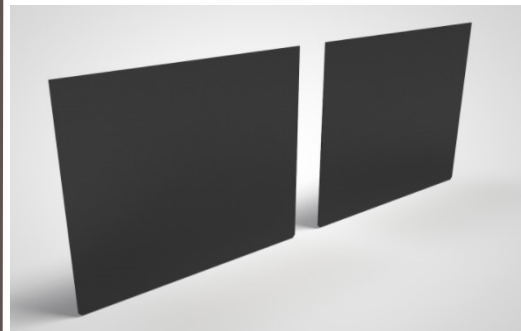

4FT LOWER FASCIA PANELS

- Optional accessory for security doors
- Used to hide product on lower 3 shelves
- Provides a clean appearance

ITEM NO	SIZE	DESCRIPTION
TOB-4SDFP-300064	(2) 2' X 2'H	BLACK FINISH
TOB-4SDFP-300069	(2) 2' X 2'H	SILVER FINISH

TOBACCO



4FT HIGH PROFILE TOBACCO RACKS

- Ships assembled
- Includes storage behind header
- Incl pushers for single packs, smokeless, vape and flat shelves for cartons

ITEM NO	SIZE	DESCRIPTION
TOB-4FT HP BK	4"W X 85"H X 16"D	BLACK FINISH
TOB-4FT HP SM	4"W X 85"H X 16"D	SILVER FINISH

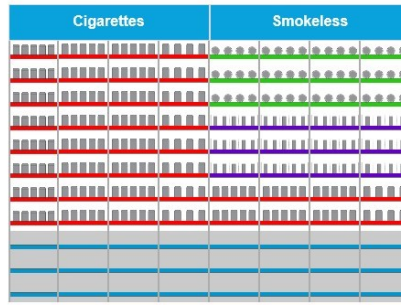

8FT HIGH PROFILE TOBACCO RACKS

- Ships assembled
- Includes storage behind header
- Incl pushers for single packs, smokeless, vape and flat shelves for cartons

ITEM NO	SIZE	DESCRIPTION
TOB-8FT HP BK	8"W X 85"H X 16"D	BLACK FINISH
TOB-8FT HP SM	8"W X 85"H X 16"D	SILVER FINISH



4FT HIGH PROFILE SECURITY DOORS

- Swing-out doors w/ clear plexi inserts
- Clear plexi insert w/ aluminum frame
- Handles include hole for lock (lock not included)

ITEM NO	SIZE	DESCRIPTION
TOB-4HSD- 291370-R1	4"W X 85"H	BLACK FINISH
TOB-4HSD- 291371-R1	4"W X 85"H	SILVER FINISH

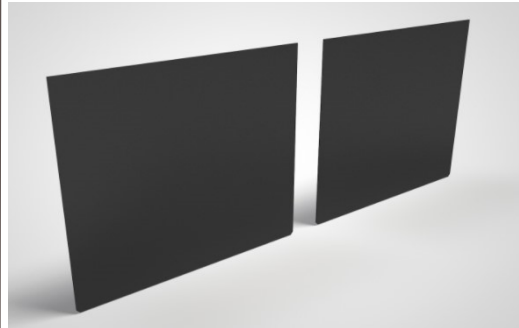

4FT LOWER FASCIA PANELS

- Optional accessory for security doors
- Used to hide product on lower 3 shelves
- Provides a clean appearance

ITEM NO	SIZE	DESCRIPTION
TOB-4SDFP-300064	(2) 2' X 2'H	BLACK FINISH
TOB-4SDFP-300069	(2) 2' X 2'H	SILVER FINISH

TOBACCO



• **TOP LOAD, 2 STREAM**

- Multiple color options available
- 32 gallon bins
- Made from recycled milk jugs

ITEM NO	SIZE	DESCRIPTION
46171	39"W X 21"D X 43"H	SELECT COLOR FOR EACH SECTION



• **TOP LOAD, 2 STREAM**

- Multiple color options available
- 32 gallon bins
- Made from recycled milk jugs

ITEM NO	SIZE	DESCRIPTION
46172	39"W X 21"D X 43"H	SELECT COLOR FOR TOPS ONLY, BOTTOM SECTIONS ARE GREY



• **FRONT LOAD, 2 STREAM**

- Multiple color options available
- 32 gallon bins
- Made from recycled milk jugs

ITEM NO	SIZE	DESCRIPTION
46173	39"W X 21"D X 43"H	SELECT COLOR FOR EACH SECTION



• **FRONT LOAD, 2 STREAM**

- Multiple color options available
- 32 gallon bins
- Made from recycled milk jugs

ITEM NO	SIZE	DESCRIPTION
46174	39"W X 21"D X 43"H	SELECT COLOR FOR DOORS ONLY, OUTER SHELL IS GREY

WASTE & RECYCLE STATIONS



• TOP LOAD, 3 STREAM

- Multiple color options available
- 32 gallon bins
- Made from recycled milk jugs

ITEM NO	SIZE	DESCRIPTION
46175	58"W X 21"D X 43"H	SELECT COLOR FOR EACH SECTION



• TOP LOAD, 3 STREAM

- Multiple color options available
- 32 gallon bins
- Made from recycled milk jugs

ITEM NO	SIZE	DESCRIPTION
46176	58"W X 21"D X 43"H	SELECT COLOR FOR TOPS ONLY, BOTTOM SECTIONS ARE GREY



• FRONT LOAD, 3 STREAM

- Multiple color options available
- 32 gallon bins
- Made from recycled milk jugs

ITEM NO	SIZE	DESCRIPTION
46177	58"W X 21"D X 43"H	SELECT COLOR FOR EACH SECTION



• FRONT LOAD, 3 STREAM

- Multiple color options available
- 32 gallon bins
- Made from recycled milk jugs

ITEM NO	SIZE	DESCRIPTION
46178	58"W X 21"D X 43"H	SELECT COLOR FOR DOORS ONLY, OUTER SHELL IS GREY

WASTE & RECYCLE STATOINS



SAFE-SITTER

- Compact and secure
- Includes hardware unit
- Custom colors available

ITEM NO	SIZE	DESCRIPTION
4310-SEAT	12"L X 20"H X 3.6"D	WHITE
4306	12"L X 20"H X 3.6"D	IVORY
4307	12"L X 20"H X 3.6"D	GRAY



DIAPER DEPOT OVAL

- Dual top-fed liner dispensers
- Shelf for personal items
- Concave bed and rounded edging

ITEM NO	SIZE	DESCRIPTION
4304-R	24.75"H X 33.5"W	WHITE
4300-R	24.75"H X 33.5"W	IVORY
4301-R	12"L X 20"H X 3.6"D	GRAY



DIAPER DEPOT VERTICAL

- Designed for narrow wall space
- Single top-fed linder dispensers
- Integrated diaper hook

ITEM NO	SIZE	DESCRIPTION
3304	22"H X 33.5"L	WHITE
3300	22"H X 33.5"L	IVORY

Front End Solutions

HUBERT® and UNFI are proud to partner together to offer a direct order smallwares program to independent retailers. We understand the challenges food retailers face, so this program offers an array of benefits, products, and services

Benefits & Services Include:

- Discounted Pricing
- Flat Rate Shipping
- Volume Discounting



Products You Need, When You Need Them

Hubert© consistently delivers fast, accurate and low-cost fulfillment services

- Over \$20M in inventory and 30,000 + items available from a single warehouse.
- Our private label, HUBERT© Brand, quality cost saving items.
- 94% of all orders ship same day, 98% within 24 hours.
- 95% of all orders ship from the HUBERT© warehouse in Ohio, reducing the number of shipments to help manage freight cost.



Project Management

Experienced team members on hand to assist with ordering & execution of smallwares standards

- Assistance developing standardized order guides
- Managing smallwares for new stores, remodels & resets
- Experts in visual merchandising
- Free consultation services

HOW TO ORDER:

- Visit our website at www.hubert.com
or call 1-800-543-7374
- Legacy Supervalu retailers use account # 809240
- Legacy UNFI retailers use account # 233779
- For convenient invoicing: Legacy Supervalu retailers on your UNFI Retailer statement. Legacy UNFI retailers HUBERT© invoice or credit card

**Contact UNFI Equipment
Services for more information**



DROP BOX SAFE

- Hinge Side deadbolt
- Programmable digital lock
- 6" drop slot

ITEM NO	SIZE	DESCRIPTION
SB2414	14"W x 14"D x 24"H	2.04 CU FT
SB2014	14"W x 14"D x 24"H	1.73 CU FT



U/C SAFE

- Heavy gauge steel construction
- 5 3/8"W x 5/8"H slot size
- compact size and easily mounted

ITEM NO	SIZE	DESCRIPTION
MS1206	6"W X 7"D X 12"H	U/C SAFE

CASH HANDLING



DEPOSITORY SAFE

- Internal locker
- B Rated solid A36 steel
- Spring loaded relocker

ITEM NO	SIZE	DESCRIPTION
MB2720ICH	27"H X 19"W x 22"D	B-RATED DEPOSITORY SAFE



D SERIES SAFE

- 2-hour Class 125 fire rating
- Programmable electronic lock
- Optional interiors allows various configurations

ITEM NO	SIZE	DESCRIPTION
DS6420	30"W X 30"D x 77"H	11.2 CU FT
DS6431	41"W x 32"D X 77"H	20.9 CU FT



FIRE & BURGLARY SAFE

- ul tl-30 rating
- TL Rated high security door
- Group II mechanical dial communication lock

ITEM NO	SIZE	DESCRIPTION
KC1814	21"W X 21"D X 25"H	1.79 CU FT
KC2218	25"W X 26"D X 28"H	3.79 CU FT
KCU3020	26"W X 31"D X 36"H	7.29 CU FT
KCU4524	30"W X 31"D X 51"H	13.13 CU FT

CASH HANDLING



KD LOCKER 1 TIER

- 1 tier locker
- Can be ordered assembled or knock-down
- 1 frame or 3 frame wide options

ITEM NO	SIZE	DESCRIPTION
U1226-1A	12"W X 12"D X 66"H	1 TIER, 1 FRAME W IN TAN OR GRAY
U3226-1	12"W X 12"D X 66"H	1 TIER, 3 FRAME W IN TAN OR GRAY



KD LOCKER 2 TIER

- 2 tier locker
- Can be ordered assembled or knock-down
- 1 frame or 3 frame wide options

ITEM NO	SIZE	DESCRIPTION
U1226-2	12"W X 12"D X 66"H	2 TIER, 1 FRAME W IN TAN OR GRAY
U3226-2	12"W X 12"D X 66"H	



KD LOCKER 3 TIER

- 3 tier locker
- Can be ordered assembled or knock-down
- 1 frame or 3 frame wide options

ITEM NO	SIZE	DESCRIPTION
U1228-3	12"W X 12"D X 66"H	3 TIER, 1 FRAME W IN TAN OR GRAY
U3228-3	12"W X 12"D X 66"H	3 TIER, 3 FRAME W IN TAN OR GRAY



KD LOCKER 6 TIER

- 6 tier locker
- Can be ordered assembled or knock-down
- 1 frame or 3 frame wide options

ITEM NO	SIZE	DESCRIPTION
U1288-6	12"W X 18"D X 78"H	6 TIER, 1 FRAME W IN TAN OR GRAY
U3288-6	12"W X 18"D X 78"H	6 TIER, 3 FRAME W IN TAN OR GRAY



KD LOCKERS W/ COAT ROD

- 16 person unit
- Coat rack in center
- Can be ordered assembled or knock-down

ITEM NO	SIZE	DESCRIPTION
U1788-16	72W X 18D X 78H	TAN OR GRAY



PANASONIC MICROWAVE

- 1000 Watt oven
- 10 Programmable memory pads
- 6 Power levels & 2 and 3 stage cooking

ITEM NO	SIZE	DESCRIPTION
NE-1054F	20-1/8"W x 16-1/2"D x 12"H	MICROWAVE, 120V, 60Hz, Single Phase



TOP-FREEZER REFRIGERATOR

- Black exterior, reversible hinges
- 15.5 cu ft total capacity
- Upfront temperature controls

ITEM NO	SIZE	DESCRIPTION
GTE18GTNRBB	32.5"D x 28"W x 67.37"H	RESIDENTIAL TOP-FREEZER REFRIGERATOR 120v; 60Hz; 15A

OFFICE/BREAKROOM FURNITURE



SET THE TONE

- Create workspaces that reflect your image
- Provide employees with areas that refresh & recharge
- Harmonize style, productivity & ergonomics



Furniture Solutions For Any Office Or Gathering Space

Offices

Conference Rooms

Breakrooms

Community Rooms

Educational Rooms

Waiting Areas

Collaborative Areas

**Contact UNFI Equipment
Services for information**

EMAIL: EQUIPMENTSERVICES@UNFI.COM

PHONE: 1.800.835.0165



CRASH CORE BOLLARD

- Plastic cover
- S10, S15 or S30 rating
- 4" diameter

ITEM NO	SIZE	DESCRIPTION
1B607307	4" DIAMETER	S10 RATING, BLACK OR GRAY PLASTIC COVER
15B600307	4" DIAMETER	S15 RATING, BLACK OR GRAY PLASTIC COVER
2B601307	4" DIAMETER	S20 RATING, BLACK OR GRAY PLASTIC COVER

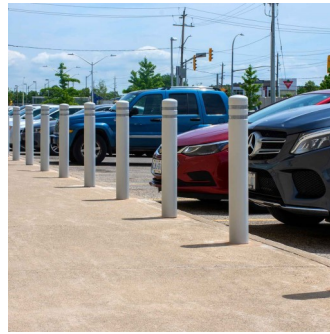

CRASH CORE BOLLARD

- Plastic cover w/ reflective detail
- S10, S15 or S30 rating
- 4" diameter

ITEM NO	SIZE	DESCRIPTION
1B608307	4" DIAMETER	S10 RATING, BLACK OR GRAY PLASTIC COVER W/ REFLECTIVE TOP
15B601307	4" DIAMETER	S15 RATING, BLACK OR GRAY PLASTIC COVER W/ REFLECTIVE TOP
2B605307	4" DIAMETER	S20 RATING, BLACK OR GRAY PLASTIC COVER W/ REFLECTIVE TOP



CRASH CORE BOLLARD

- Stainless steel cover
- S10, S15 or S30 rating
- 6" diameter

ITEM NO	SIZE	DESCRIPTION
1B609905	6" DIAMETER	S10 RATING, STAINLESS STEEL COVER
15B602905	6" DIAMETER	S15 RATING, STAINLESS STEEL COVER
2B600905	6" DIAMETER	S20 RATING, STAINLESS STEEL COVER



BETTER FOOD. BETTER FUTURE.

EQUIPMENT SERVICES

**11840 Valley View Road
Eden Prairie, MN 55344**