

EQUIPMENT SERVICES

2024 PRODUCT CATALOG





BAKERY

Equipment Services



Inside this section:

| | |
|--|-----|
| Rack Ovens & Proofers | 4 |
| Cake Decorating & Donuts | 6 |
| Dishwashers | 8 |
| Bread Slicers | 9 |
| Nesting Tables | 10 |
| Display Tables | 14 |
| Upright Displays | 17 |
| Bakery Islands | 19 |
| Bakery Cases | 23 |
| Specialty | 27 |
| Tortilla Warmers | 30 |
| Signs & Sign Holders | 31 |
| Custom Millwork | 40 |
| Bakery Smallwares | 41 |
| Aftermarket Parts | 42 |
| Refrigeration—see refrigeration section | N/A |

Contact UNFI Equipment Services for member pricing & ordering
equipmentservices@unfi.com or 1.800.835.0165

Items in this catalog are subject to change & availability



ROLL-IN RACK OVEN

- Accommodates one single rack
- Standard type ii hood
- Eight stage baking, with variable air speed & adjustable air flow

| ITEM NO | SIZE | DESCRIPTION |
|---------|-------------------------|--|
| SRO1G | 55"W x 51"D x 100 7/8"H | GAS SINGLE RACK OVEN, 208/240V, 1/3 PHASE |
| SRO1E | 55"W x 51"D x 100 7/8"H | ELECTRIC SINGLE RACK OVEN, 208V, 1/3 PHASE |



ROLL-IN RACK OVEN

- Accommodates 2 single or 1 double rack
- Standard type ii hood
- Eight stage baking, with variable air speed & adjustable air flow

| ITEM NO | SIZE | DESCRIPTION |
|---------|---------------------|---|
| SRO2G | 72"W x 62"D x 103"H | GAS DOUBLE RACK OVEN, 208/240V, 1/3 PHASE |
| SRO2E | 72"W x 62"D x 103"H | ELECTRIC DOUBLE OVEN, 208V, 3 PHASE |



ROLL-IN PROOFER W/ FLOOR

- Accommodates one single racks
- Glass or stainless steel doors
- Solid state heat & humidity controls

| ITEM NO | SIZE | DESCRIPTION |
|----------|---------------------------|--|
| DRIP1 | 33"Wx46-1/2"D x 86"H | PROOFER, SINGLE RACK, 120/208/240V, 1PHASE |
| DRIP1TLO | 38-1/2" x 56-1/2"D x 86"H | PROOFER, 2 SINGLE RACKS OR 1 DOUBLE RACK, 120/208/240V, 1PHASE |



ROLL-IN PROOFER W/ FLOOR

- Accommodates two single racks
- Glass or stainless steel doors
- Solid state heat & humidity controls

| ITEM NO | SIZE | DESCRIPTION |
|---------|---------------------------|--|
| E236R | 67"W x 40-1/2"D x 84"H | PROOFER, 2 SINGLE RACK, 120/208/240V, 1PHASE |
| E236TLO | 77-1/2" x 48-1/2"D x 84"H | PROOFER, 4 SINGLE RACKS OR 2 DOUBLE RACK, 120/208/240V, 1PHASE |



OVEN RACK

- 6" Spaced, 10 pan capacity side load
- "B" style Baxter lift
- Aluminum frame, stainless steel Baxter lift rails w/ high temp casters

| ITEM NO | SIZE | DESCRIPTION |
|-------------|--------------------------|--|
| AOVS2610BX2 | 69.75"H x 18"D x 28.38"W | ALUMINUM 10 PAN SIDE LOAD SINGLE OVEN RACK |
| AOVS2615BX2 | 69.75"H x 18"D x 28.38"W | ALUMINUM 15 PAN SIDE LOAD SINGLE OVEN RACK |
| AOVD2610BX2 | 69.75"H x 28.38"D x 36"W | ALUMINUM 20 PAN SIDE LOAD DOUBLE RACK |
| OTHER SIZE | OPTIONS ARE AVAILABLE | REACH OUT TO EQUIPMENT SERVICES FOR MORE INFORMATION |

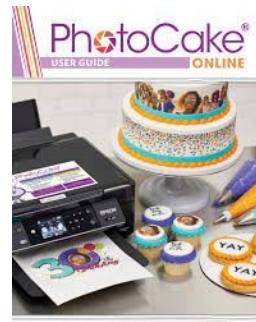

CAKE DECORATING SYSTEM

- Built-in design tools for custom images
- Never miss a sale with virtual inventory
- Complete system- everything you need to start decorating!

| ITEM NO | SIZE | DESCRIPTION |
|---------------------|--|--|
| PHOTOCAKE IV SYSTEM | SEVERAL COMPONENTS WILL NEED ITS OWN SPACE. 115 VAC/ 60 Hz | INCL: MONITOR, CONTROLLER, SCANNER PRINTER, POS STARTER KIT & CAKE DESIGNS |
| 37666 | | AIRBRUSH- COMPLETE COMPRESSOR |
| 13656 | | AIRBRUSH- SINGLE ACTION GUN |
| 940 | | STAND COVER FOR PHOTOCAKE IV |

CAKE DECORATING PRINTER

- Printer & starter kit
- Must have your own computer
- POS, door cling, head card, promo stickers, display cake & posters included

| ITEM NO | SIZE | DESCRIPTION |
|------------------|-------------------------|------------------------|
| PHOTOCAKE ONLINE | 11.9"W x 17.2"D x 5.7"H | PHOTOCAKE PRINTER ONLY |

CAKE DECORATING & DONUTS



DONUT OPEN KETTLE FRYER

- 18" x 26" frying area
- 95lb shortening capacity
- Accommodates EZ melt shortening melter-filter

| ITEM NO | SIZE | DESCRIPTION |
|------------|--------------------|---|
| 718L | 46"W x 64"H x 39"D | GAS DONUT FRYER |
| 718LG-1541 | 11LB | SUBMERGER FOR 718LG |
| EZ MELT 18 | 21"W x 27"D x 24"H | EZ-MELT, MELTER/FILTER150# FOR 18X26 FRYER, 120V |
| F00010001 | 17-1/2"W x 33"H | CAKE DONUT DEPOSITORS, TYPE F, 120/60/1PH COLUMN MOUNTING BRACKETS & POST FOR DEPOSITOR |
| 405 | | |



DONUT GLAZER

- Accommodates 18" X 26" screens
- Glaze capacity is 40lbs
- Stainless steel frame & kettle, aluminum applicator, includes casters

| ITEM NO | SIZE | DESCRIPTION |
|---------|-----------------------|---|
| HG-18 | 35" H X 38" L X 25" W | DONUT GLAZER ACCOMMODATES 18x26 SCREENS |
| HG-24 | 35" H X 38" L X 32" W | DONUT GLAZER ACCOMMODATES 24" X 24" SCREENS |
| HG-34 | 35" H X 48" L X 32" W | DONUT GLAZER ACCOMMODATES 24" X 34" SCREENS |



ICING TABLE

- (4) 13" stainless steel icing bowls
- Compatible w/ all Belshaw Adamatic systems
- Bowls are gently heated w/warm water, keeping the icing in condition longer

| ITEM NO | SIZE | DESCRIPTION |
|---------|--------------------|---|
| H&I - 4 | 31"W x 31"D x 62"H | 4 BOWL ICING WARMER, 120/240V-50/60hz-1ph |
| H&I - 2 | 19"W x 31"D x 35"H | 2 BOWL ICING WARMER, 120/240V-50/60hz-1ph |



80 QT PLANETARY MIXER

- #12 Hub, 4 fix speeds, digital controls
- Interlocked guard w/ ingredient shoot
- Incl: spiral dough hook, whip & beater, bowl truck, power bowl lift

| ITEM NO | SIZE | DESCRIPTION |
|------------|----------------------------|---|
| SP80PL | 30-1/2"W x 38-3/5"D x 35"H | 80QT PLANETARY MIXER, 208V, 3 Phase, 3 hp REACH OUT TO EQUIPMENT SERVICES FOR MORE INFORMATION |
| OTHER SIZE | OPTIONS ARE AVAILABLE | |



POT/PAN/UTENSIL WASHER

- Door type, high temp w/ built in booster
- Front loading, split- door design
- 20 pan capacity, 2 flat grids, 2 tray racks & 1 flat bottom rack

| ITEM NO | SIZE | DESCRIPTION |
|---------------|-----------------------------|--|
| PW20-1 | 55-5/8"W x 37-3/16"D x 78"H | DISHMACHINE, 20 PAN CAP, 208-240V & 480V/60 Hz/3 ph |
| PW10-1 | 34.86"W x 37.2"D x 78"H | DISHMACHINE, 20 PAN CAP, 208-240V & 480V/60 Hz/3 ph |
| VENTFANKIT-PW | | POWERED VENT FAN CONTROL FOR PW MODELS |



VENTLESS DISHWASHER

- Door type, high temp w/ built in booster
- Front loading, split- door design
- 20 pan capacity, 2 flat grids, 2 tray racks & 1 flat bottom rack

| ITEM NO | SIZE | DESCRIPTION |
|----------|-----------------------------|--|
| PW20eR-1 | 55-5/8"W x 37-3/16"D x 89"H | VENTLESS DISHMACHINE, 20 PAN CAP, 208-240V/60 Hz/3 ph |
| PW10eR-1 | 34.86"W x 37.2"D x 89"H | VENTLESS DISHMACHINE, 20 PAN CAP, 208-240V/60 Hz/3 ph |



VARIETY BREAD SLICER

- Floor model, compact sturdy design
- Ideal for slicing up to 150 loaves / day
- Slices virtually all bread varieties cleanly & quickly

| ITEM NO | SIZE | DESCRIPTION |
|---------|----------------------|---|
| 777-N | 20.5"W X 47"H X 24"D | BREAD SLICER, FLOOR MODEL, 1/2HP, 1PH, 60HZ |



FRONT LOAD BREAD SLICER

- Countertop model, smallest footprint
- Large bread capacity- up to 16" loaves
- Smooth, quiet operation with minimal vibration

| ITEM NO | SIZE | DESCRIPTION |
|------------|--------------------------------|--|
| 732-N | 26 3/8"W X 24 5/8"H | BREAD SLICER, COUNTERTOP MODEL, 1/2HP, 1PH, 60HZ |
| 0732-25018 | 21-3/8"W X 33-1/8"H X 18-5/8"D | STAND FOR BREAD SLICER, COUNTERTOP MODEL |



GRAVITY FEED SLICER

- Floor model, heavy duty casters
- ProGuard feature to support safety
- Batch slicing for higher volume retail and in-store bakeries

| ITEM NO | SIZE | DESCRIPTION |
|---------|--------------------------|---|
| 797-N | 22.75"W X 62"H X 44.25"D | GRAVITY BREAD SLICER, FLOOR MODEL, 1/2HP, 1PH, 60HZ |



BAGEL & BUN SLICER

- Countertop model, robust design
- Ideal for on-premise slicing
- Safe & efficient alternative to manual slicing

| ITEM NO | SIZE | DESCRIPTION |
|------------|---------------------|--|
| 723-N | 29 3/4"W X 22 3/4"H | BAGEL & BUN SLICER, COUNTERTOP MODEL, 1/2HP, 1PH, 60HZ |
| 0702-25035 | | OPTIONAL RETURN CHUTE FOR 723-N |

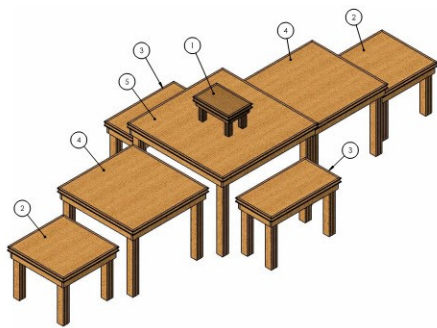

LARGE 8-PIECE SET W/ PTM

- Flexible set allows for massive capacity
- Push tables in as product sells
- Set includes price tag molding around each table

| ITEM NO | SIZE | DESCRIPTION |
|---------------|---|---|
| BAK-1241 SETO | (1) 48x48x36"H, (2) 38x38x30"H, (2) 28x28x22"H, (2) 35x18x24"H, (1) 18x12x10"H TOPPER | Full 8-piece set w/ PTM Choice of finish |
| BAK-1240 OAK | 48" X 48" X 35.5"H | Single additional large table w/ PTM |
| BAK-1237 OAK | 28" X 28" X 22"H | Single additional small table w/ PTM |
| BAK-1259 O | 35" X 18" X 24"H | Single additional side table w/ PTM |

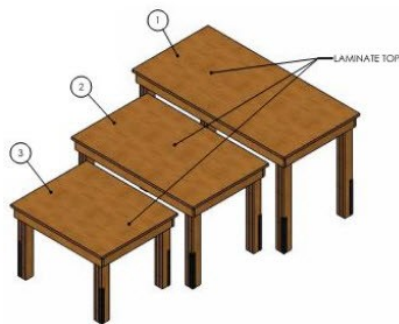

LAMINATE TOP NESTING TABLES

- Multiple sets to choose from
- Waterfall style steps down to one side
- Square legs in solid wood with vertical corner guards

| ITEM NO | SIZE | DESCRIPTION |
|--------------------|---|-------------------|
| NT-100 SET OSB | L: 60"x35", M: 48"x30", S: 36"x25" - All 30"d | LARGE 3 TABLE SET |
| NT-166 SET O1505B | L: 48"x29", M: 36"x24", S: 30"x19" - All 30"d | SMALL 3 TABLE SET |
| NT-177 SET O 1505B | L: 36"x29", M: 30"x24" - All 30"d | SMALL 2 TABLE SET |

NESTING TABLES

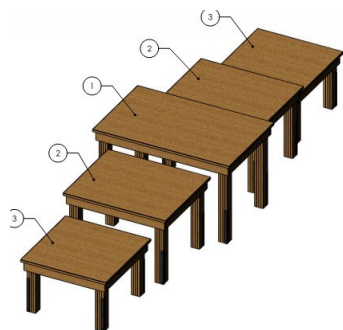

LAMINATE TOP NESTING TABLES

- Multiple sets to choose from
- Double sided style
- Square legs in solid wood with vertical corner guards

| ITEM NO | SIZE | DESCRIPTION |
|-------------------|--|-------------------|
| NT-171 SET O1505B | (1) 48 x 30 x 29"H, (2) 36 x 30 x 24"H, (2) 30 x 24 x 19"H | SMALL 5 TABLE SET |
| NT-42355 SET OSB | (1) 60 x 30 x 35"H, (2) 48 x 30 x 30"H | LARGE 3 TABLE SET |



SMALL NESTING TABLE SET

- Compact 4 table set
- Combine multiple sets for larger display
- Tables have tapered legs w/ nail in glides

| ITEM NO | SIZE | DESCRIPTION |
|-----------|--|------------------|
| NT-13 OAK | (1)36" X 36" X 39"H, (1)26"W X 18"D X 30"H, (1)24" W X 18" D X 30" H, (1) 14" W X 16" D X 21" H | CHOICE OF FINISH |



OAK NESTING TABLES

- 3 table set
- Lightweight and easy to move
- Solid wood tables w/ tapered legs

| ITEM NO | SIZE | DESCRIPTION |
|---------------|---|------------------|
| NT-03 SET OAK | (1) 28" X 30" X 26-7/8"H, (1) 38" X 30" X 31-5/8"H & (1) 48" X 30" X 36-3/8"H | CHOICE OF FINISH |

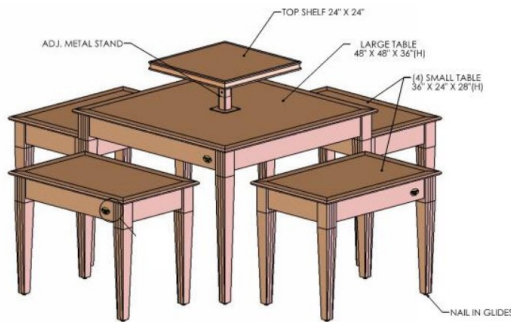

5 TABLE SET W/ TOPPER

- 5 table set + topper
- Create large, multi-level displays
- Tables have tapered legs w/ nail in glides

| ITEM NO | SIZE | DESCRIPTION |
|------------------|---|------------------|
| NT-12 ADJ. TOP O | (1) 48" X 48" X 36"H WITH BUILT IN ADJ. HEIGHT TOPPER 24" X 24", (4) 36"W X 24"W X 28"H | CHOICE OF FINISH |

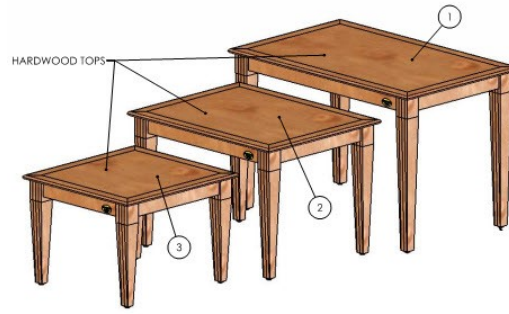

OAK NESTING TABLES

- 3 table set, similar to NT-03 but shorter
- Lightweight and easy to move
- Solid wood tables w/ tapered legs

| ITEM NO | SIZE | DESCRIPTION |
|---------|---|------------------|
| NT-08 | (1) 48" X 30" X 30"H, (1) 38" X 30" X 24"H & (1) 28" X 30" X 21"H | CHOICE OF FINISH |



DOUBLE SIDED NESTING TABLES

- 5 table set
- Double sided style
- Tables have tapered legs w/ nail in glides

| ITEM NO | SIZE | DESCRIPTION |
|-----------|--|------------------|
| NT-14 OAK | (1) 48" X 30" X 36"H, (2) 28"W X 22"W X 27"H, (2) 21"W X 16"D X 18"H | CHOICE OF FINISH |



METAL FRAME TABLES

- 3 table set
- Modern Style
- Black metal frame with laminate tops

| ITEM NO | SIZE | DESCRIPTION |
|---------------------|--|--------------------|
| 38658-A NT-38658 RD | LG: 50"W X 20"D X 36"H, MD: 41"W X 20"D X 29"H, SM: 33"W X 20"D X 21"H | CHOICE OF LAMINATE |

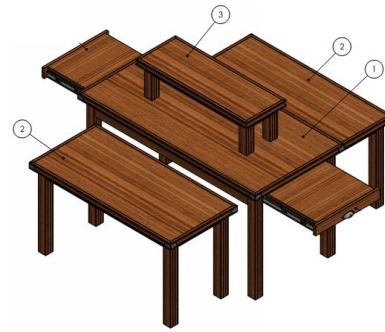

NESTING TABLE W/ PULL-OUT SHELVES

- 4 table set + topper
- Main table w/ pull-out shelves on sides
- Set includes price tag molding around each table

| ITEM NO | SIZE | DESCRIPTION |
|------------------|---|------------------|
| NT-37404 R0001RS | (1) 60x36x32"h, (2) 47x22x26"h, (1) 37x13x11"h TOPPER | CHOICE OF FINISH |



SMALL TABLE W/ PULL-OUT SHELVES

- Compact display
- Includes 16 pull-out shelves
- Solid wood table w/ square legs

| ITEM NO | SIZE | DESCRIPTION |
|-----------------|------------------|----------------|
| BAK-40656 POPWH | 36" X 36" X 36"H | NAIL-IN GLIDES |
| BAK-41820 POPWH | 36" X 36" X 36"H | CASTERS |



LARGE TABLE W/ PULL-OUT SHELVES

- Flexible display
- Includes 12 pull-out shelves
- Solid wood table w/ square legs

| ITEM NO | SIZE | DESCRIPTION |
|------------------|------------------|----------------|
| BAK-40655 POPWH | 54" X 33" X 36"H | NAIL-IN GLIDES |
| BAK-41821 POP155 | 54" X 33" X 36"H | CASTERS |



DRAWER-STYLE NESTING TABLES

- 6 table set including topper
- Multi-level merchandising
- Fixtures sit on tack-glides

| ITEM NO | SIZE | DESCRIPTION |
|------------|---|------------------|
| NT0413-O-P | (1) 48" X 28" TABLE W/ PULL-OUT SHELVES (2) 35-3/4" X 18-1/2" NESTING TABLES (2) 18-1/2" X 15-3/4" NESTING TABLES (1) 25-1/2" X 13-1/2" TOPPER | CHOICE OF FINISH |



DRAWER-STYLE NESTING TABLES

- 4 table set including topper
- Multi-level merchandising
- Fixtures sit on tack-glides

| ITEM NO | SIZE | DESCRIPTION |
|------------|---|------------------|
| NT0414-O-P | (1) 48" X 28" TABLE W/ PULL-OUT SHELVES (2) 35-3/4" X 18-1/2" NESTING TABLES (1) 25-1/2" X 13-1/2" TOPPER | CHOICE OF FINISH |



4-WAY CONVERTIBLE TABLE

- Flexible display w/ multiple shelves & levels
- All shelves include PTM
- Casters for mobility

| ITEM NO | SIZE | DESCRIPTION |
|---------------|-----------------------------------|------------------|
| BAK-1092 O SB | 74"W x 78"L x 42"H FULLY EXTENDED | CHOICE OF FINISH |

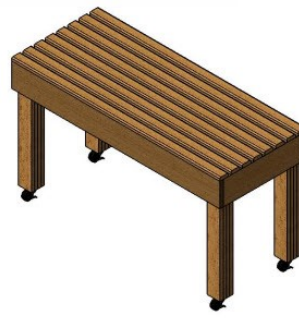

BAKERY PROMO TABLE

- Compact slat top table
- Casters for mobility
- Great for displaying promo items near entrance and checkouts

| ITEM NO | SIZE | DESCRIPTION |
|--------------|----------------|------------------|
| PROMO-TBL 03 | 48"Lx20"Dx28"H | CHOICE OF FINISH |



2-TIER MOBILE BAKERY TABLE

- Solid top w/ black bumper
- Fixed lower shelf
- Casters for mobility

| ITEM NO | SIZE | DESCRIPTION |
|-----------|------------------|------------------|
| BAK-127 O | 72" X 30" X 34"H | CHOICE OF FINISH |



2-TIER BAKERY TABLE

- Maple top & lower shelf
- Black metal legs
- Leveling feet

| ITEM NO | SIZE | DESCRIPTION |
|---------------|------------------|------------------|
| BAK-37774 MBK | 72" X 30" X 34"H | CHOICE OF FINISH |

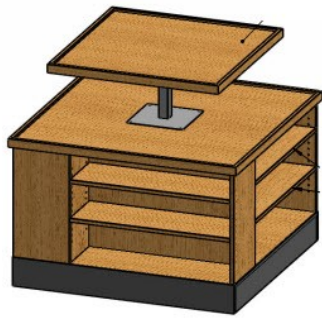

4x4 TABLE W/ TOPPER

- Solid top w/ 3x3 fixed topper
- Lower cabinet has 2 adj shelves per side
- 6" toe-kick

| ITEM NO | SIZE | DESCRIPTION |
|----------------|------------------|------------------|
| DISP-38857 OSB | 48" X 48" X 45"H | CHOICE OF FINISH |

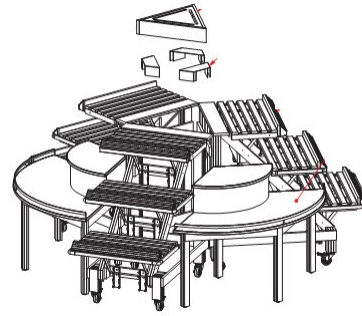

SIGNATURE TABLE SET

- Incls: (3) 3-tier tables & (2) wedge tables
- 2 size options
- 3rd corner can be filled with basket sets or an additional wedge table

| ITEM NO | SIZE | DESCRIPTION |
|-----------------|-------------------------------------|-------------|
| SIG-SET 020SBSV | 28"W 3-TIER (APPROX 9FT FOOTPRINT) | SMALL SET |
| SIG-SET 010SBSV | 42"W 3-TIER (APPROX 10FT FOOTPRINT) | LARGE SET |
| TBL458 O SB | 34"D (FITS BOTH SETS) | EXTRA WEDGE |

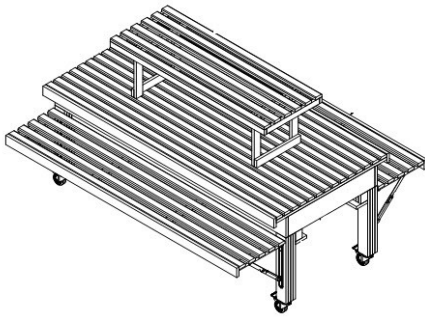

"COOKIE TABLE"

- Slat top table w/ removable topper
- Topper stores underneath when not in use
- Has flip-up shelves on both sides as well as casters for mobility

| ITEM NO | SIZE | DESCRIPTION |
|-----------------|--------------------|------------------|
| TBL 458 SLATTED | 72"L X 36"W X 29"H | CHOICE OF FINISH |

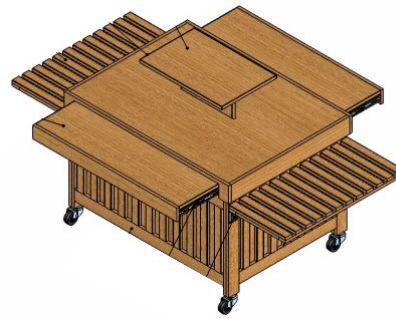

EXPANDABLE TABLE

- Table has a solid top & topper
- Slat sides & flip-up shelves
- 2 solid pull out drawers

| ITEM NO | SIZE | DESCRIPTION |
|----------------|--------------------|------------------|
| BAK-1052 OSVSB | 48"L X 36"W X 33"H | CHOICE OF FINISH |

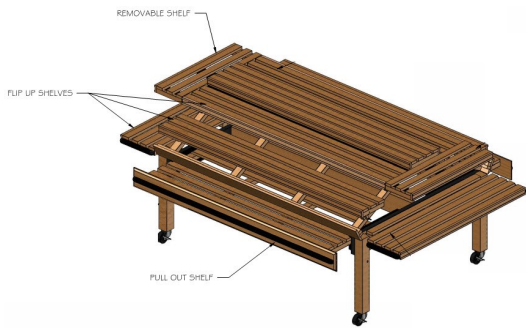

6FT CONVERTIBLE TABLE

- Flexible display w/ multiple shelves & levels
- All shelves include PTM
- Casters for mobility

| ITEM NO | SIZE | DESCRIPTION |
|----------|--------------------|------------------|
| ET0570-O | 72"L X 49"W X 41"H | CHOICE OF FINISH |

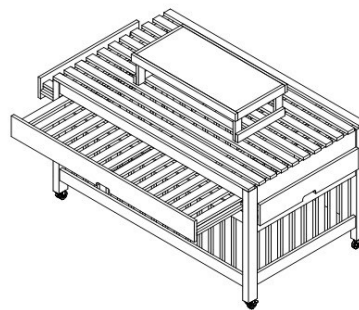

SLAT TOP EXPANDABLE TABLE

- Slat top table w/ removable topper
- Slat sides w/ pull-out drawers
- Casters for mobility

| ITEM NO | SIZE | DESCRIPTION |
|-----------|--------------------|------------------|
| SA0763-PL | 60"L X 36"W X 41"H | CHOICE OF FINISH |

DISPLAY TABLES



EXPANDABLE SLAT TABLE

- Table has a solid top & topper
- Slat sides & flip-up shelves
- 2 solid pull out drawers

| ITEM NO | SIZE | DESCRIPTION |
|---------|--------------------|------------------|
| BM0895 | 48"L X 36"W X 40"H | CHOICE OF FINISH |

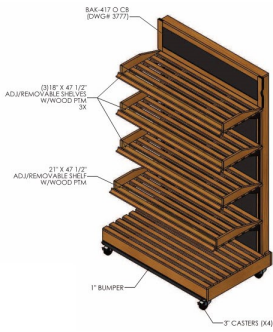

BAKERY WALL SHELVING - HIGH

- (4) Adjustable slat shelves with PTM.
- Chalkboard sign holder & solid back panel
- Casters for mobility

| ITEM NO | SIZE | DESCRIPTION |
|------------------|-------------------|------------------|
| BAK-1091 O SB-V3 | 3"W X 81"H X 30"D | CHOICE OF FINISH |
| BAK-1089 O SB-V3 | 4"W X 81"H X 30"D | CHOICE OF FINISH |
| BAK-1090 O SB-V3 | 5"W X 81"H X 30"D | CHOICE OF FINISH |



BAKERY WALL SHELVING - LOW

- (3) Adjustable slat shelves with PTM.
- Solid back panels
- Casters for mobility

| ITEM NO | SIZE | DESCRIPTION |
|---------------|-------------------|------------------|
| BAK-40420 OSB | 3"W X 60"H X 30"D | CHOICE OF FINISH |
| BAK-1381 OSB | 4"W X 60"H X 30"D | CHOICE OF FINISH |
| BAK-1149 OAK | 3"W X 48"H X 30"D | CHOICE OF FINISH |
| BAK-1150 OAK | 4"W X 48"H X 30"D | CHOICE OF FINISH |

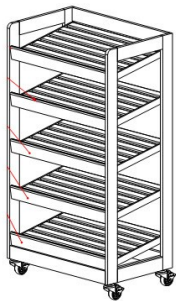

UPRIGHT PROMO DISPLAYS

- Fixed sloped shelves at 10°
- 5 & 6 shelf option
- Casters for mobility

| ITEM NO | SIZE | DESCRIPTION |
|-------------|------------------|-------------|
| BAK-431 OAK | 31"Wx 20"Dx 57"H | 5-SHELF |
| BAK-425 OAK | 31"Wx 20"Dx 68"H | 6-SHELF |



UPRIGHT PROMO DISPLAY

- (5) Fixed sloped shelves at 10°
- Chalkboard sign holder
- Casters for mobility

| ITEM NO | SIZE | DESCRIPTION |
|---------|------------------------|-------------|
| BAK-457 | 31"W X 20"D X 60 1/2"H | 5-SHELF |



MULTI-USE BAKERY DISPLAY

- Includes shelves & baguette holders
- Casters for mobility
- Will hold a variety of baked goods including specialty breads and baguettes

| ITEM NO | SIZE | DESCRIPTION |
|--------------|--------------------|------------------|
| BAK-586 O KR | 36"W X 20"D X 53"H | CHOICE OF FINISH |



A-FRAME DISPLAY

- (5) Fixed slat shelves with PTM
- Use against a wall or back-to-back
- Leveling legs

| ITEM NO | SIZE | DESCRIPTION |
|--------------|--------------------|------------------|
| BAK-42441 RO | 24"W X 24"D X 60"H | CHOICE OF FINISH |

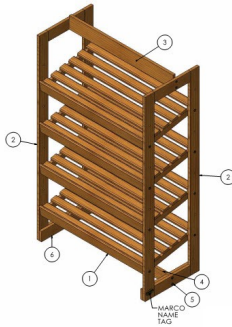

SIMPLE BAKERY SHELVING

- (4) Adjustable slat shelves
- Use against a wall or back-to-back
- Casters for mobility

| ITEM NO | SIZE | DESCRIPTION |
|-------------|--------------------|------------------|
| BAK-412 OAK | 36"W X 18"D X 60"H | CHOICE OF FINISH |

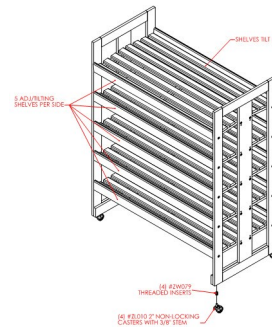

DOUBLE SIDED BAKERY SHELVING

- (5) Shelves per side
- Shelves can be used flat or at a 5° angle
- Casters for mobility

| ITEM NO | SIZE | DESCRIPTION |
|-------------|--------------------|------------------|
| BAK-420 OAK | 48"W X 24"D X 61"H | CHOICE OF FINISH |



4-TIER BAKERY ISLAND

- Great display for any department
- 4 slat shelves with PTM
- Casters for mobility

| ITEM NO | SIZE | DESCRIPTION |
|-----------|--------------------|------------------|
| BAK-522 O | 40"W X 40"D X 48"H | CHOICE OF FINISH |

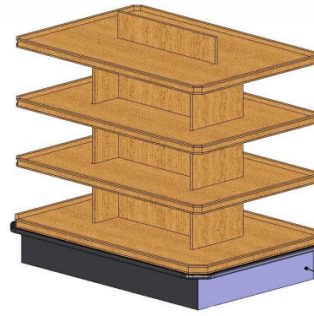

4-SHELF BAKERY ISLAND

- Great display for any department
- 4 solid shelves with PTM
- Casters for mobility

| ITEM NO | SIZE | DESCRIPTION |
|----------------|--------------------|------------------|
| KR CRACKER OSC | 60"W X 42"D X 54"H | CHOICE OF FINISH |



LP BAKERY ISLAND CENTER

- 2 adjustable shelves per side
- Fixed top shelf & base w/ bumper
- Casters for mobility

| ITEM NO | SIZE | DESCRIPTION |
|-----------------|----------------------------|------------------|
| BAK-1097 OAK SV | 45"W x 42" OA DEPTH x 45"H | CHOICE OF FINISH |
| BAK-1256 OSB | 24"W x 42" OA DEPTH x 45"H | CHOICE OF FINISH |



LP BAKERY ISLAND END

- 2 adjustable shelves per side
- Fixed top shelf & base w/ bumper
- Casters for mobility

| ITEM NO | SIZE | DESCRIPTION |
|-----------------|--------------------|------------------|
| BAK-1098 OAK SV | 42"W x 20"D x 45"H | CHOICE OF FINISH |



HI-BASE ISLAND CENTER

- 3 adjustable shelves per side
- 18"h base
- Casters for mobility

| ITEM NO | SIZE | DESCRIPTION |
|-----------|----------------------------|------------------|
| BAK-583 O | 54"H X 45"W x 45" OA DEPTH | CHOICE OF FINISH |



HI-BASE ISLAND END

- 3 adjustable shelves
- 18"h base
- Casters for mobility

| ITEM NO | SIZE | DESCRIPTION |
|-----------|---------------------|------------------|
| BAK-567 O | 54"H X 45"W x 27" D | CHOICE OF FINISH |



BAKERY ISLAND CENTER

- 3 adjustable shelves per side
- Low base w/ PTM & bumper
- Casters for mobility

| ITEM NO | SIZE | DESCRIPTION |
|---------------|----------------------------|------------------|
| BAK-1173 OSB | 54"H X 45"W x 45" OA DEPTH | CHOICE OF FINISH |
| BAK-36868 OSB | 54"H X 24"W x 45" OA DEPTH | CHOICE OF FINISH |

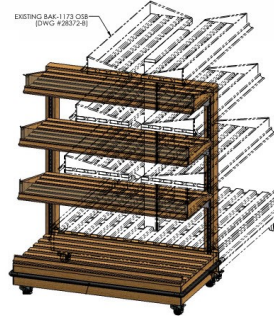

BAKERY ISLAND SHELVED END

- 3 adjustable shelves
- Low base w/ PTM & bumper
- Casters for mobility

| ITEM NO | SIZE | DESCRIPTION |
|-----------------|---------------------|------------------|
| BAK-1199 EC OSB | 54"H X 45"W x 27" D | CHOICE OF FINISH |

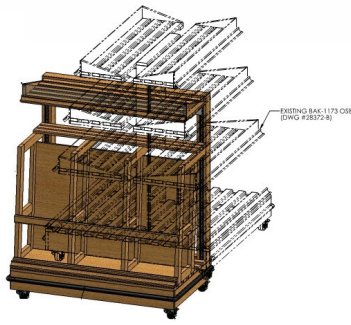

BAKERY ISLAND BAGUETTE END

- 1 adjustable shelf w/ baguette display
- Low base w/ PTM & bumper
- Casters for mobility

| ITEM NO | SIZE | DESCRIPTION |
|-----------------|---------------------|------------------|
| BAK-1200 EC OSB | 54"H X 45"W x 27" D | CHOICE OF FINISH |



BAKERY ISLAND BIN END

- 2 adj shelves, 1 adj shelf with 4 clear bins
- Low base w/ PTM & bumper
- Casters for mobility

| ITEM NO | SIZE | DESCRIPTION |
|-----------------|--------------------|------------------|
| BAK-1513 EC OSB | 54"H X 45"W X 27"D | CHOICE OF FINISH |



BAKERY ISLAND NESTING END

- 3 table set with topper
- For use as bakery island end cap
- Can also be used as stand-alone table set

| ITEM NO | SIZE | DESCRIPTION |
|----------------|--|------------------|
| NT-101 SET OAK | L: 47"x19"x35"H, M: 37"x19"x30"H, S: 27"x19"x25"H, TOP: 22"Wx12"Dx10"H | CHOICE OF FINISH |



LARGE BAKERY ISLAND

- Extremely flexible and customizable
- Incls: adj table tops, risers, steps & top-per
- 3 pull-out drawers per side, lower storage on ends, casters

| ITEM NO | SIZE | DESCRIPTION |
|--------------|--------------------|------------------|
| BAK-520 O DH | 87"L X 39"W X 54"H | CHOICE OF FINISH |

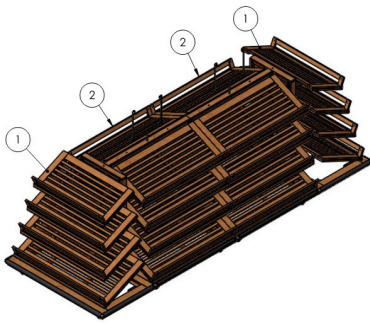

BAKERY ISLAND SET

- Complete island set
- 4 shelves per side w/ PTM & product stops
- Set incl: (2) 4ft bakery units & (2) end caps

| ITEM NO | SIZE | DESCRIPTION |
|--------------|-----------------------------|------------------|
| BAK-1539 OBV | 158" OAL X 57.5" OAW X 53"H | CHOICE OF FINISH |

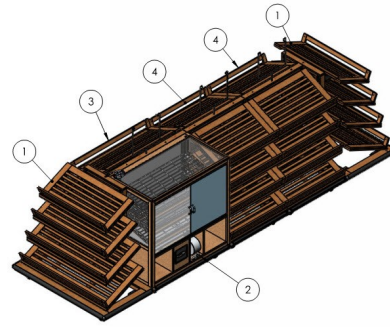

COMBO BAKERY ISLAND SET

- Pastry case incorporated into island
- 4 shelves per side w/ PTM & product stops
- Set incl: (1) 4ft pastry combo unit, (2) 3ft bakery units & (2) end caps

| ITEM NO | SIZE | DESCRIPTION |
|--------------|-----------------------------|------------------|
| BAK-1540 OBV | 182" OAL X 57.5" OAW X 53"H | CHOICE OF FINISH |



2DR LOW PROFILE CASE

- (3) shelves per door w/ PTM & LED lighting
- Pkg ledge w/ box storage, tissue/trash holders
- Holds (6) std 18x26 pastry trays *not in-

| ITEM NO | SIZE | DESCRIPTION |
|----------------------------|------------------------|--------------------|
| C-DC2-404356-SLD-SHL-BLK-1 | 39 1/2"W X 43"D X 56"H | SLIDING REAR DOORS |
| C-DC2-404356-SHL-BLK-1 | 39 1/2"W X 43"D X 56"H | SOLID BACK |



3DR LOW PROFILE CASE

- (3) shelves per door w/ PTM & LED lighting
- Pkg ledge w/ box storage, tissue/trash holders
- Holds (9) std 18x26 pastry trays *not in-

| ITEM NO | SIZE | DESCRIPTION |
|----------------------------|------------------------|--------------------|
| C-DC3-594356-SLD-SHL-BLK-1 | 58 1/2"W X 43"D X 56"H | SLIDING REAR DOORS |
| C-DC3-594356-SHL-BLK-1 | 58 1/2"W X 43"D X 56"H | SOLID BACK |



4DR LOW PROFILE CASE

- (3) shelves per door w/ PTM & LED lighting
- Pkg ledge w/ box storage, tissue/trash holders
- Holds (12) std 18x26 pastry trays *not in-

| ITEM NO | SIZE | DESCRIPTION |
|----------------------------|------------------------|--------------------|
| C-DC4-774356-SLD-SHL-BLK-1 | 77 1/4"W X 43"D X 56"H | SLIDING REAR DOORS |
| C-DC4-774356-SHL-BLK-1 | 77 1/4"W X 43"D X 56"H | SOLID BACK |



2DR STANDARD CASE

- (4) shelves per door w/ PTM & LED lighting
- Pkg ledge w/ box storage, tissue/trash holders
- Holds (8) std 18x26 pastry trays *not in-

| ITEM NO | SIZE | DESCRIPTION |
|------------------------------|------------------------|--------------------|
| C-DC2-A-404281-SLD-SHL-BLK-1 | 39 1/2"W X 42"D X 81"H | SLIDING REAR DOORS |
| C-DC2-A-404281-SHL-BLK-1 | 39 1/2"W X 42"D X 81"H | SOLID BACK |



3DR STANDARD CASE

- (4) shelves per door w/ PTM & LED lighting
- Pkg ledge w/ box storage, tissue/trash holders
- Holds (12) std 18x26 pastry trays *not in-

| ITEM NO | SIZE | DESCRIPTION |
|------------------------------|------------------------|--------------------|
| C-DC3-A-594281-SLD-SHL-BLK-1 | 58 1/2"W X 42"D X 81"H | SLIDING REAR DOORS |
| C-DC3-A-594281-SHL-BLK-1 | 58 1/2"W X 42"D X 81"H | SOLID BACK |



4DR STANDARD CASE

- (4) shelves per door w/ PTM & LED lighting
- Pkg ledge w/ box storage, tissue/trash holders
- Holds (16) std 18x26 pastry trays *not in-

| ITEM NO | SIZE | DESCRIPTION |
|------------------------------|------------------------|--------------------|
| C-DC4-A-774281-SLD-SHL-BLK-1 | 77 1/4"W X 42"D X 81"H | SLIDING REAR DOORS |
| C-DC4-A-774281-SHL-BLK-1 | 77 1/4"W X 42"D X 81"H | SOLID BACK |



OPEN DISPLAY CASE - LEFT/CENTER/RIGHT

OPEN BAKERY CASE

- (4) slat shelves w/ PTM & plexi product stops
- Includes LED lighting
- Open cases match door cases to complete you bakery line-up

| ITEM NO | SIZE | DESCRIPTION |
|----------------|--------------------|----------------|
| C-DCL-484281-1 | 48"W X 42"D X 81"H | LEFT SECTION |
| C-DCL-604281-1 | 60"W X 42"D X 81"H | LEFT SECTION |
| C-DCL-724281-1 | 72"W X 42"D X 81"H | LEFT SECTION |
| B11007 | 36"W X 42"D X 81"H | CENTER SECTION |
| C-DCC-484281-1 | 48"W X 42"D X 81"H | CENTER SECTION |
| C-DCC-604281-1 | 60"W X 42"D X 81"H | CENTER SECTION |
| C-DCC-724291-1 | 72"W X 42"D X 81"H | CENTER SECTION |
| B11003 | 36"W X 42"D X 81"H | RIGHT SECTION |
| C-DCR-484281-1 | 48"W X 42"D X 81"H | RIGHT SECTION |
| C-DCR-604281-1 | 60"W X 42"D X 81"H | RIGHT SECTION |
| C-DCR-724281-1 | 72"W X 42"D X 81"H | RIGHT SECTION |

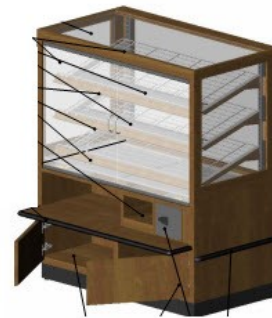

LOW PROFILE 2DR

- (3) wire shelves w/ wood PTM & LED lighting
- Pkg ledge w/ box storage & tissue holder
- Lower storage & positive pressure fan

| ITEM NO | SIZE | DESCRIPTION |
|--------------|--------------------|--------------------|
| BAK-952 OAK | 50"W X 27"D X 56"H | SOLID BACK |
| BAK-41501 RO | 50"W X 27"D X 56"H | SLIDING REAR DOORS |

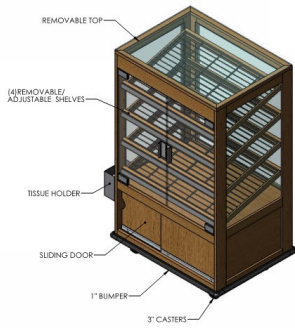

MOBILE DISPLAY CART

- (4) adjustable shelves w/ PTM
- Lower cabinet for storage
- Includes tissue holder

| ITEM NO | SIZE | DESCRIPTION |
|----------------|--------------------|------------------|
| BAK-1055 OSVSB | 32"W X 24"D X 55"H | CHOICE OF FINISH |

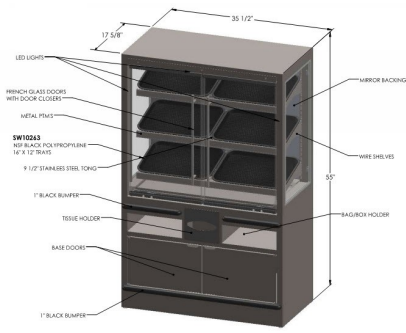

NARROW METAL PASTRY CASE

- (4) shelves w/ PTM
- LED lighting
- Includes mirror back, bag/box holder, lower storage, fan & (6) 12x16 trays

| ITEM NO | SIZE | DESCRIPTION |
|----------|--------------------|-----------------|
| BAK-1328 | 36"W X 18"D X 55"H | SOLID METAL TOP |
| BAK-1360 | 36"W X 18"D X 55"H | SOLID GLASS TOP |



COMBO PRETZEL/BAGEL/PASTRY CASE

- Shop around unit w/ casters for mobility
- LED lighting, tissue/trash/box storage
- One side for pastries on shelves, one side for pretzels or bagels on hooks.

| ITEM NO | SIZE | DESCRIPTION |
|-------------------|--------------------|------------------|
| BAK-36895 RO2155B | 48"W x 52"D x 66"H | CHOICE OF FINISH |

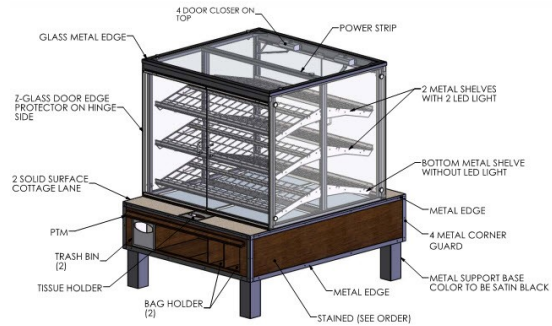

DOUBLE SIDED PASTRY CASE

- Low-profile shop around unit
- (3) shelves per side w/ PTM & LED lighting
- Includes tissue, trash & bag/box holders

| ITEM NO | SIZE | DESCRIPTION |
|---------------|--------------------|------------------|
| BAK-37023 OSB | 50"W X 64"D X 63"H | CHOICE OF FINISH |

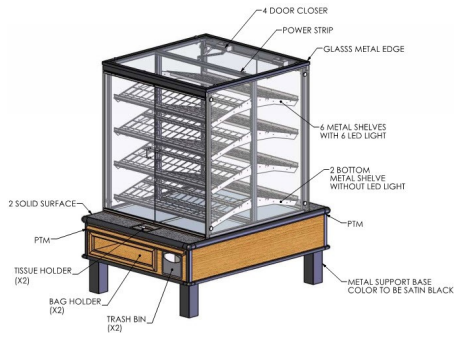

DOUBLE SIDED PASTRY CASE

- High-profile shop around unit
- (4) shelves per side w/ PTM & LED lighting
- Includes tissue, trash & bag/box holders

| ITEM NO | SIZE | DESCRIPTION |
|---------------|--------------------|------------------|
| BAK-37022 05B | 48"W X 62"D X 72"H | CHOICE OF FINISH |

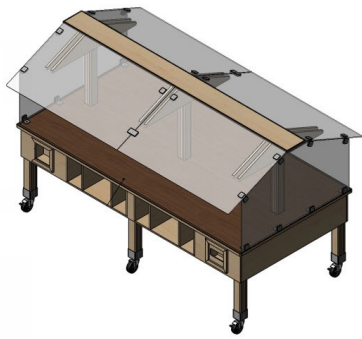

ARTISAN BREAD TABLE

- Table incl. top and side sneeze guards
- Tissue holders and bag/box storage
- Create a unique display using baskets and/or risers (not included)

| ITEM NO | SIZE | DESCRIPTION |
|------------------|-----------------------|------------------|
| BAK-39799 BLAMSB | 72" L X 48" D X 60" H | CHOICE OF FINISH |
| BAK-36452 BLAMSB | 96" L X 48" D X 60" H | CHOICE OF FINISH |

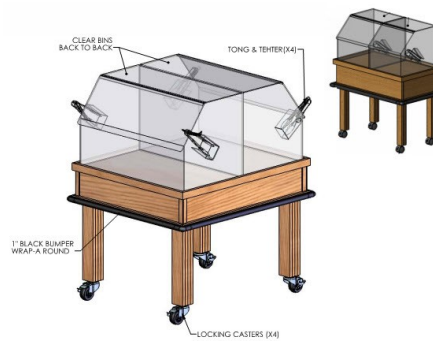

BOLILLO TABLES

- Two table sizes available
- Bins include tethered tongs
- Casters for mobility

| ITEM NO | SIZE | DESCRIPTION |
|---------------|-----------------------|--------------|
| BAK-37375 POP | 30" W x 18" D X 38" H | SINGLE SIDED |
| BAK-696 OAK | 32" W x 34" D X 45" H | DOUBLE SIDED |

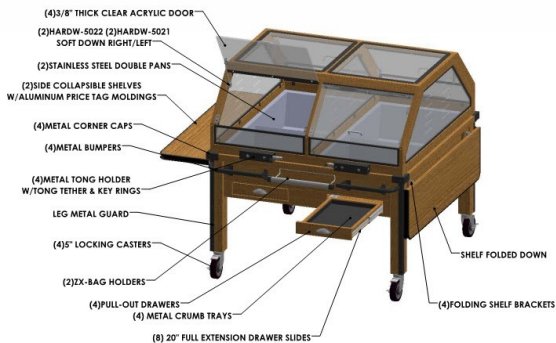

EXTRA LARGE BOLILLO TABLE

- Deep SS pans shoppable from both sides
- Flip-up side shelves, pull-out drawers
- Casters for mobility

| ITEM NO | SIZE | DESCRIPTION |
|--------------|-----------------------|------------------|
| BAK-1275 OSB | 48" W x 48" D x 48" H | CHOICE OF FINISH |

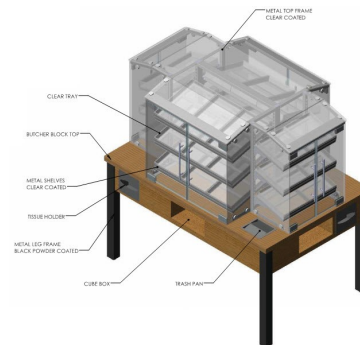

FRESH COOKIE CART

- Table with 4-sided glass case
- 3 shelves per side include LED lighting and trays
- Tissue, trash and box holders included

| ITEM NO | SIZE | DESCRIPTION |
|---------------|-------------------|------------------|
| BAK-1461 MCLR | 60" X 39" X 61" H | CHOICE OF FINISH |

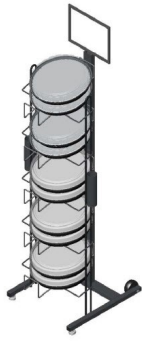

COOKIE & CAKE HOLDER

- Vertical rack w/ 5 angled shelves
- Made to hold large round cookies or cakes
- Includes 8.5" x 11" sign holder and has

| ITEM NO | SIZE | DESCRIPTION |
|---------------|--------------------|------------------|
| MET-CH 001 GB | 55"H X 19"D X 17"W | BLACK POWDERCOAT |

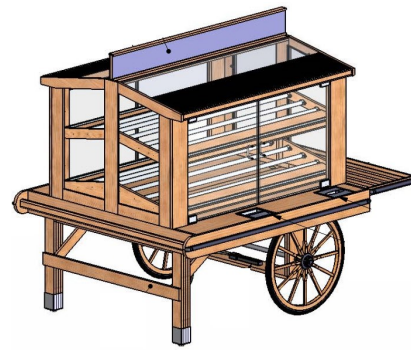

MUFFIN CART

- 2 Sided cart w/ 2 shelves per side
- Light above each shelf
- Includes chalkboard header, tissue & trash holders, flip-up side shelf

| ITEM NO | SIZE | DESCRIPTION |
|----------------|--------------------------------|------------------|
| M-CART-017 OAK | 60" CASE/ 82"OAL x 60"D x 68"H | CHOICE OF FINISH |

SPECIALTY



MOBILE DISPLAY CART

- 2 Sided cart w/ 2 shelves per side
- LED lighting
- Sized to fit standard 13"L x 18"D half muffin pan or pastry trays

| ITEM NO | SIZE | DESCRIPTION |
|------------------|--------------------------------|------------------|
| C-MDC-484662-M-1 | 48" CASE/ 66"OAL x 46"D x 62"H | CHOICE OF FINISH |
| CD0212-O | 30" CASE/ 60"OAL x 46"D x 62"H | CHOICE OF FINISH |



FLAT BASE BREAD BAR

- 3 sided glass shield & solid surface countertop
- Rear storage
- Adjustable shelves with wood PTM

| ITEM NO | SIZE | DESCRIPTION |
|---------|------------------------|------------------|
| BM1682 | 48"W X 40"D X 40"/59"H | CHOICE OF FINISH |
| BM1683 | 60"W X 40"D X 40"/59"H | CHOICE OF FINISH |
| BM1684 | 72"W X 40"D X 40"/59"H | CHOICE OF FINISH |
| BM1681 | 84"W X 40"D X 40"/59"H | CHOICE OF FINISH |

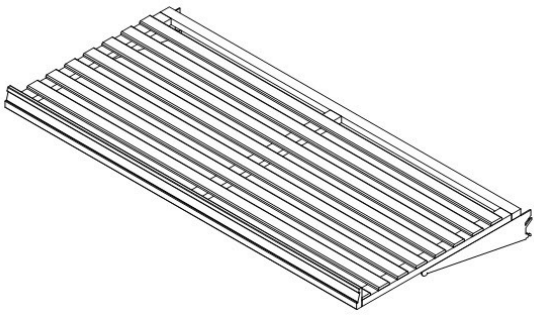

BAKERY SHELF - CLEAR FINISH

- Slat shelf w/ PTM in multiple sizes
- Brackets fit Lozier or Madix uprights
- Choice of bracket color: Almond or Black

| ITEM NO | SIZE | DESCRIPTION |
|---------|-------------|--------------|
| BS-4815 | 48"W X 15"D | CLEAR FINISH |
| BS-4817 | 48"W X 17"D | CLEAR FINISH |
| BS-4820 | 48"W X 20"D | CLEAR FINISH |
| BS-4822 | 48"W X 22"D | CLEAR FINISH |
| BS-3615 | 36"W X 15"D | CLEAR FINISH |
| BS-3617 | 36"W X 17"D | CLEAR FINISH |
| BS-3620 | 36"W X 20"D | CLEAR FINISH |
| BS-3622 | 36"W X 22"D | CLEAR FINISH |
| BS-3019 | 30"W X 19"D | CLEAR FINISH |
| BS-3022 | 30"W X 22"D | CLEAR FINISH |

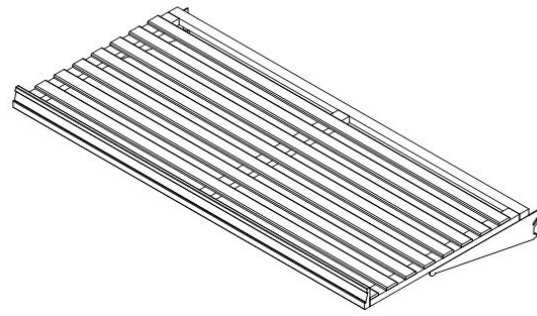

BAKERY SHELF - STAINED

- Slat shelf w/ PTM in multiple sizes
- Brackets fit Lozier or Madix uprights
- Choice of bracket color: Almond or Black, and choice of standard stain

| ITEM NO | SIZE | DESCRIPTION |
|-----------|-------------|--------------------------|
| BS-4815-S | 48"W X 15"D | CHOICE OF STANDARD STAIN |
| BS-4817-S | 48"W X 17"D | CHOICE OF STANDARD STAIN |
| BS-4820-S | 48"W X 20"D | CHOICE OF STANDARD STAIN |
| BS-4822-S | 48"W X 22"D | CHOICE OF STANDARD STAIN |
| BS-3615-S | 36"W X 15"D | CHOICE OF STANDARD STAIN |
| BS-3617-S | 36"W X 17"D | CHOICE OF STANDARD STAIN |
| BS-3620-S | 36"W X 20"D | CHOICE OF STANDARD STAIN |
| BS-3622-S | 36"W X 22"D | CHOICE OF STANDARD STAIN |
| BS-3019-S | 30"W X 19"D | CHOICE OF STANDARD STAIN |
| BS-3022-S | 30"W X 22"D | CHOICE OF STANDARD STAIN |

SPECIALTY



SMALL TORTILLA WARMER

- Temp adjustable from 100° to 140° F
- Lighted interior
- Optional wire basket for ease of loading and custom graphics available

| ITEM NO | SIZE | DESCRIPTION |
|--------------------|--------------------|--------------------------|
| TM WARM S2 | 29"W X 17"D X 33"H | WARMER W/ COROPLAST BODY |
| TM WARM S2 M | 29"W X 17"D X 33"H | WARMER W/ METAL BODY |
| TM WARM S2/400-166 | NA | ARTWORK |



LARGE TORTILLA WARMER

- Temp adjustable from 100° to 140° F
- Lighted interior
- Optional wire basket for ease of loading and custom graphics available

| ITEM NO | SIZE | DESCRIPTION |
|--------------------|--------------------|--------------------------|
| TM WARM S3 | 41"W X 17"D X 33"H | WARMER W/ COROPLAST BODY |
| TM WARM S3 M | 41"W X 17"D X 33"H | WARMER W/ METAL BODY |
| TM WARM S3/400-166 | NA | ARTWORK |



TABLE TOP TORTILLA WARMER

- Temp adjustable from 90° to 140° F
- Lighted interior
- Use on a countertop. Custom graphics also available

| ITEM NO | SIZE | DESCRIPTION |
|-------------------|--------------------|----------------------|
| TM TT H80 | 49"W X 26"D X 18"H | WARMER W/ METAL BODY |
| TM TT H80/400-166 | NA | ARTWORK |



OAK A-FRAME

- Sign area is 36" h x 24" w
- Blank cast acrylic panels
- Perfect for use with Liquichalk pens

| ITEM NO | SIZE | DESCRIPTION |
|---------|-------------|-------------|
| 2121098 | 42"H X 24"W | 6" LEGS |



CHALKBOARD A-FRAME

- Indoor/Outdoor
- Double sided
- Portable

| ITEM NO | SIZE | DESCRIPTION |
|---------|-------------|-------------|
| 37101 | 16"L X 36"H | 2-SIDED |



CHALKBOARD A-FRAME

- Wood frame
- Double sided
- Portable

| ITEM NO | SIZE | DESCRIPTION |
|---------|-------------|-------------|
| 21360 | 24"L X 47"H | 2-SIDED |



ACRYLIC CHALKBOARD W/ BASE

- Sold per each
- Perfect for use with Liquichalk pens
- Decor Neutral color

| ITEM NO | SIZE | DESCRIPTION |
|---------|--------------------------|----------------------------------|
| 2310020 | 1-3/4"W X 2-3/4"H | WRITE-ON/WIPE OFF, FREE-STANDING |
| 1400002 | LIQUICHALK MARKER KIT #1 | 14 MARKERS, VARIOUS COLORS |
| 1400003 | LIQUICHALK MARKER KIT #2 | 10 MARKERS, VARIOUS COLORS |



RECTANGULAR CHALKBOARD

- Cedar frame
- Single Sided
- Wall Mount

| ITEM NO | SIZE | DESCRIPTION |
|---------|-------------|--------------|
| 48913 | 36"L X 24"H | SINGLE SIDED |
| 68912 | 24"L X 18"H | SINGLE SIDED |



ARCHED CHALKBOARD

- Cedar frame
- Single Sided
- Wall Mount

| ITEM NO | SIZE | DESCRIPTION |
|---------|-------------|--------------|
| 61658 | 24"L X 26"H | SINGLE SIDED |



GALVANIZED CHALKBOARD TAG

- Hanging hook
- Use on bins, baskets & other containers
- For use with chalk or chalk markers

| ITEM NO | SIZE | DESCRIPTION |
|---------|-------------------|--------------|
| 68631 | 4-3/4"L X 4-1/2"H | SINGLE SIDED |



WRITE-ON EASEL

- Double sided
- Wood base
- Matte black finish

| ITEM NO | SIZE | DESCRIPTION |
|---------|----------------|--------------|
| 55210 | 8-1/2"L X 11"H | DOUBLE SIDED |



CAPSTONE CHALKBOARD

- Double sided
- Wood base
- Matte black acrylic

| ITEM NO | SIZE | DESCRIPTION |
|---------|-----------|--------------|
| 63996 | 4"L X 6"H | DOUBLE SIDED |



RUSTIC TENT SIGN

- Black metal
- Easel base
- For use with dustless white chalk

| ITEM NO | SIZE | DESCRIPTION |
|---------|-----------|--------------|
| 95381 | 4"L X 3"H | SINGLE SIDED |



TABLETOP CHALKBOARD

- Matte black P95 material
- Wood base
- Perfect for bakery displays

| ITEM NO | SIZE | DESCRIPTION |
|---------|---------------|------------------------------------|
| 25781 | 3-1/2"L X 2"H | HORIZONTAL OR VERTICAL ORIENTATION |
| 28925 | 4"L X 6"H | HORIZONTAL OR VERTICAL ORIENTATION |



WOODEN PEG SIGN

- Sold in packs of 3
- Matte black P95 acrylic
- For use with chalk or chalk markers

| ITEM NO | SIZE | DESCRIPTION |
|---------|-------------------|--------------|
| 41348 | 3-1/2"L X 2-1/2"H | SINGLE SIDED |
| 46708 | 3"L X 4"H | SINGLE SIDED |



MINI SUCTION CUP SIGN HOLDER

- Sold in packs of 5
- Clear plastic
- For use on flat surfaces, (2) 3/4" dia adhesive cups for mounting

| ITEM NO | SIZE | DESCRIPTION |
|---------|---------------|--------------|
| 98105 | 3-1/2"L X 2"H | SINGLE SIDED |



SUCTION CUP SIGN HOLDER

- Sold in packs of 5
- Clear plastic
- For use on flat surfaces, (2) 3/4" dia adhesive cups for mounting

| ITEM NO | SIZE | DESCRIPTION |
|---------|-----------|--------------|
| 43992 | 4"L X 2"H | SINGLE SIDED |



RUBBER LINED-CLIP ON SIGN HOLDER

- Sold in packs of 6
- Black plastic
- Holds paper signs

| ITEM NO | SIZE | DESCRIPTION |
|---------|------|-----------------------------|
| 81782 | 4"H | RUBBER GRIP OPENS TO 1-1/8" |



SIGN HOLDER WITH VINYL POUCH

- Sold in packs of 6
- Clear plastic
- Clip with anti-slip coating & knuckle tilt

| ITEM NO | SIZE | DESCRIPTION |
|---------|-------------------|-----------------------------|
| 41858 | 5-1/2"L X 3-1/2"H | RUBBER GRIP OPENS TO 1-1/8" |
| 19743 | 3-5/8"L X 2-1/2"H | RUBBER GRIP OPENS TO 1-1/8" |

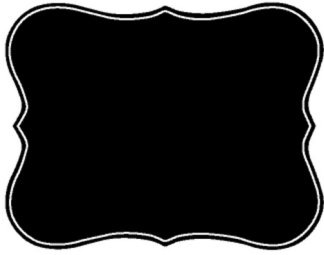

VINTAGE SCROLL TAG

- Sold in packs of 12
- Write-on/Wipe-off
- Black matte finish

| ITEM NO | SIZE | DESCRIPTION |
|---------|-------------------|--|
| 48992 | 4-1/2"L X 3-1/2"H | TEMP RANGE 10 TO 225 DEGREES FARENHEIT |

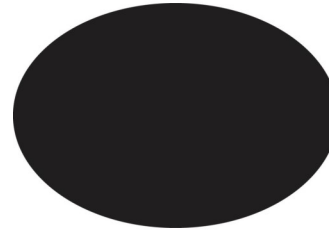

OVAL FLEX TEMP TAG

- Sold in packs of 12
- Write-on/Wipe-off
- Black matte finish

| ITEM NO | SIZE | DESCRIPTION |
|---------|-------------------|--|
| 85014 | 3-1/4"L X 2-1/4"H | TEMP RANGE 10 TO 225 DEGREES FARENHEIT |



CHALK MARKER

- White
- Fine tip
- For use on chalkboards & write-on/wipe-off signs

| ITEM NO | SIZE | DESCRIPTION |
|---------|------|-----------------------------|
| 71872 | 3mm | WHITE FINE TIP CHALK MARKER |



LARGE CLIP ON SIGN HOLDER

- Clear plastic spring clip options
- Sold in packs of 6
- Fits on fixture edge up to 1-1/8" thick

| ITEM NO | SIZE | DESCRIPTION |
|---------|---------------|-------------------------------|
| 39673 | 4-1/4"L X 3"W | ACCEPTS UP TO 1/4" THICK SIGN |



SOLID BACK CLIP ON SIGN HOLDER

- Clear or Black plastic options
- Single Sided
- Sold per each

| ITEM NO | SIZE | DESCRIPTION |
|-------------|-------------------|-------------------|
| B3430014-10 | 3-1/2"H X 5-1/2"W | BLACK SPRING CLIP |
| B3430013-10 | 3-1/2"H X 5-1/2"W | CLEAR SPRING CLIP |



BK02 BAKERY GRAPHIC

- Wall mount with included hardware
- Various size options available
- Direct print on 4.5mm thick material

| ITEM NO | SIZE | DESCRIPTION |
|-----------------|---------------------|--------------|
| BK02-GRA-2X3-WM | 1'-11" H X 2'-11" W | SINGLE SIDED |
| BK02-GRA-2X4-WM | 1'-11" H X 3'-11" W | SINGLE SIDED |
| BK02-GRA-4X4-WM | 3'-11" H X 3'-11" W | SINGLE SIDED |
| BK02-GRA-4X6-WM | 3'-11" H X 5'-11" W | SINGLE SIDED |
| BK02-GRA-5X8-WM | 4'-11" H X 7'-11" W | SINGLE SIDED |



BK04 BAKERY GRAPHIC

- Wall mount with included hardware
- Various size options available
- Direct print on 4.5mm thick material

| ITEM NO | SIZE | DESCRIPTION |
|-----------------|---------------------|--------------|
| BK04-GRA-2X3-WM | 1'-11" H X 2'-11" W | SINGLE SIDED |
| BK04-GRA-2X4-WM | 1'-11" H X 3'-11" W | SINGLE SIDED |
| BK04-GRA-4X4-WM | 3'-11" H X 3'-11" W | SINGLE SIDED |
| BK04-GRA-4X6-WM | 3'-11" H X 5'-11" W | SINGLE SIDED |
| BK04-GRA-5X8-WM | 4'-11" H X 7'-11" W | SINGLE SIDED |



BK05 BAKERY GRAPHIC

- Wall mount with included hardware
- Various size options available
- Direct print on 4.5mm thick material

| ITEM NO | SIZE | DESCRIPTION |
|-----------------|---------------------|--------------|
| BK05-GRA-2X3-WM | 1'-11" H X 2'-11" W | SINGLE SIDED |
| BK05-GRA-2X4-WM | 1'-11" H X 3'-11" W | SINGLE SIDED |
| BK05-GRA-4X4-WM | 3'-11" H X 3'-11" W | SINGLE SIDED |
| BK05-GRA-4X6-WM | 3'-11" H X 5'-11" W | SINGLE SIDED |
| BK05-GRA-5X8-WM | 4'-11" H X 7'-11" W | SINGLE SIDED |



BK06 BAKERY GRAPHIC

- Wall mount with included hardware
- Various size options available
- Direct print on 4.5mm thick material

| ITEM NO | SIZE | DESCRIPTION |
|-----------------|---------------------|--------------|
| BK06-GRA-2X3-WM | 1'-11" H X 2'-11" W | SINGLE SIDED |
| BK06-GRA-2X4-WM | 1'-11" H X 3'-11" W | SINGLE SIDED |
| BK06-GRA-4X4-WM | 3'-11" H X 3'-11" W | SINGLE SIDED |
| BK06-GRA-4X6-WM | 3'-11" H X 5'-11" W | SINGLE SIDED |
| BK06-GRA-5X8-WM | 4'-11" H X 7'-11" W | SINGLE SIDED |



BK07 BAKERY GRAPHIC

- Wall mount with included hardware
- Various size options available
- Direct print on 4.5mm thick material

| ITEM NO | SIZE | DESCRIPTION |
|-----------------|---------------------|--------------|
| BK07-GRA-2X3-WM | 1'-11" H X 2'-11" W | SINGLE SIDED |
| BK07-GRA-2X4-WM | 1'-11" H X 3'-11" W | SINGLE SIDED |
| BK07-GRA-4X4-WM | 3'-11" H X 3'-11" W | SINGLE SIDED |
| BK07-GRA-4X6-WM | 3'-11" H X 5'-11" W | SINGLE SIDED |
| BK07-GRA-5X8-WM | 4'-11" H X 7'-11" W | SINGLE SIDED |



BK08 BAKERY GRAPHIC

- Wall mount with included hardware
- Various size options available
- Direct print on 4.5mm thick material

| ITEM NO | SIZE | DESCRIPTION |
|-----------------|---------------------|--------------|
| BK08-GRA-2X3-WM | 1'-11" H X 2'-11" W | SINGLE SIDED |
| BK08-GRA-2X4-WM | 1'-11" H X 3'-11" W | SINGLE SIDED |
| BK08-GRA-4X4-WM | 3'-11" H X 3'-11" W | SINGLE SIDED |
| BK08-GRA-4X6-WM | 3'-11" H X 5'-11" W | SINGLE SIDED |
| BK08-GRA-5X8-WM | 4'-11" H X 7'-11" W | SINGLE SIDED |



BK09 BAKERY GRAPHIC

- Wall mount with included hardware
- Various size options available
- Direct print on 4.5mm thick material

| ITEM NO | SIZE | DESCRIPTION |
|-----------------|---------------------|--------------|
| BK09-GRA-2X3-WM | 1'-11" H X 2'-11" W | SINGLE SIDED |
| BK09-GRA-2X4-WM | 1'-11" H X 3'-11" W | SINGLE SIDED |
| BK09-GRA-4X4-WM | 3'-11" H X 3'-11" W | SINGLE SIDED |
| BK09-GRA-4X6-WM | 3'-11" H X 5'-11" W | SINGLE SIDED |
| BK09-GRA-5X8-WM | 4'-11" H X 7'-11" W | SINGLE SIDED |



BK10 BAKERY GRAPHIC

- Wall mount with included hardware
- Various size options available
- Direct print on 4.5mm thick material

| ITEM NO | SIZE | DESCRIPTION |
|-----------------|---------------------|--------------|
| BK10-GRA-2X3-WM | 1'-11" H X 2'-11" W | SINGLE SIDED |
| BK10-GRA-2X4-WM | 1'-11" H X 3'-11" W | SINGLE SIDED |
| BK10-GRA-4X4-WM | 3'-11" H X 3'-11" W | SINGLE SIDED |
| BK10-GRA-4X6-WM | 3'-11" H X 5'-11" W | SINGLE SIDED |
| BK10-GRA-5X8-WM | 4'-11" H X 7'-11" W | SINGLE SIDED |



BK11 BAKERY GRAPHIC

- Wall mount with included hardware
- Various size options available
- Direct print on 4.5mm thick material

| ITEM NO | SIZE | DESCRIPTION |
|-----------------|---------------------|--------------|
| BK11-GRA-2X3-WM | 1'-11" H X 2'-11" W | SINGLE SIDED |
| BK11-GRA-2X4-WM | 1'-11" H X 3'-11" W | SINGLE SIDED |
| BK11-GRA-4X4-WM | 3'-11" H X 3'-11" W | SINGLE SIDED |
| BK11-GRA-4X6-WM | 3'-11" H X 5'-11" W | SINGLE SIDED |
| BK11-GRA-5X8-WM | 4'-11" H X 7'-11" W | SINGLE SIDED |



BK12 BAKERY GRAPHIC

- Wall mount with included hardware
- Various size options available
- Direct print on 4.5mm thick material

| ITEM NO | SIZE | DESCRIPTION |
|-----------------|---------------------|--------------|
| BK12-GRA-2X3-WM | 1'-11" H X 2'-11" W | SINGLE SIDED |
| BK12-GRA-2X4-WM | 1'-11" H X 3'-11" W | SINGLE SIDED |
| BK12-GRA-4X4-WM | 3'-11" H X 3'-11" W | SINGLE SIDED |
| BK12-GRA-4X6-WM | 3'-11" H X 5'-11" W | SINGLE SIDED |
| BK12-GRA-5X8-WM | 4'-11" H X 7'-11" W | SINGLE SIDED |



BK13 BAKERY GRAPHIC

- Wall mount with included hardware
- Various size options available
- Direct print on 4.5mm thick material

| ITEM NO | SIZE | DESCRIPTION |
|-----------------|---------------------|--------------|
| BK13-GRA-2X3-WM | 1'-11" H X 2'-11" W | SINGLE SIDED |
| BK13-GRA-2X4-WM | 1'-11" H X 3'-11" W | SINGLE SIDED |
| BK13-GRA-4X4-WM | 3'-11" H X 3'-11" W | SINGLE SIDED |
| BK13-GRA-4X6-WM | 3'-11" H X 5'-11" W | SINGLE SIDED |
| BK13-GRA-5X8-WM | 4'-11" H X 7'-11" W | SINGLE SIDED |



BK14 BAKERY GRAPHIC

- Wall mount with included hardware
- Various size options available
- Direct print on 4.5mm thick material

| ITEM NO | SIZE | DESCRIPTION |
|-----------------|---------------------|--------------|
| BK14-GRA-2X3-WM | 1'-11" H X 2'-11" W | SINGLE SIDED |
| BK14-GRA-2X4-WM | 1'-11" H X 3'-11" W | SINGLE SIDED |
| BK14-GRA-4X4-WM | 3'-11" H X 3'-11" W | SINGLE SIDED |
| BK14-GRA-4X6-WM | 3'-11" H X 5'-11" W | SINGLE SIDED |
| BK14-GRA-5X8-WM | 4'-11" H X 7'-11" W | SINGLE SIDED |



BK15 BAKERY GRAPHIC

- Wall mount with included hardware
- Various size options available
- Direct print on 4.5mm thick material

| ITEM NO | SIZE | DESCRIPTION |
|-----------------|---------------------|--------------|
| BK15-GRA-2X3-WM | 1'-11" H X 2'-11" W | SINGLE SIDED |
| BK15-GRA-2X4-WM | 1'-11" H X 3'-11" W | SINGLE SIDED |
| BK15-GRA-4X4-WM | 3'-11" H X 3'-11" W | SINGLE SIDED |
| BK15-GRA-4X6-WM | 3'-11" H X 5'-11" W | SINGLE SIDED |
| BK15-GRA-5X8-WM | 4'-11" H X 7'-11" W | SINGLE SIDED |



BK16 BAKERY GRAPHIC

- Wall mount with included hardware
- Various size options available
- Direct print on 4.5mm thick material

| ITEM NO | SIZE | DESCRIPTION |
|-----------------|---------------------|--------------|
| BK16-GRA-2X3-WM | 1'-11" H X 2'-11" W | SINGLE SIDED |
| BK16-GRA-2X4-WM | 1'-11" H X 3'-11" W | SINGLE SIDED |
| BK16-GRA-4X4-WM | 3'-11" H X 3'-11" W | SINGLE SIDED |
| BK16-GRA-4X6-WM | 3'-11" H X 5'-11" W | SINGLE SIDED |
| BK16-GRA-5X8-WM | 4'-11" H X 7'-11" W | SINGLE SIDED |

CUSTOM MILLWORK



SEASONED MANUFACTURERS

- Extensive convenience & grocery retail experience
- Creative solutions
- Transform & enhance on any budget



**Nationwide
First-Class
Custom Millwork**

Custom Displays

Custom Fixtures

Service Counters

Bars & Seating Counters

Front End & Ecommerce

Full millwork packages

Installation Services

**Contact UNFI Equipment
Services for information**

EMAIL: EQUIPMENTSERVICES@UNFI.COM

PHONE: 1.800.835.0165

Bakery Solutions

HUBERT® and UNFI are proud to partner together to offer a direct order smallwares program to independent retailers. We understand the challenges food retailers face, so this program offers an array of benefits, products, and services

Benefits & Services Include:

- Discounted Pricing
- Flat Rate Shipping
- Volume Discounting



Products You Need, When You Need Them

Hubert© consistently delivers fast, accurate and low-cost fulfillment services

- Over \$20M in inventory and 30,000 + items available from a single warehouse.
- Our private label, HUBERT© Brand, quality cost saving items.
- 94% of all orders ship same day, 98% within 24 hours.
- 95% of all orders ship from the HUBERT© warehouse in Ohio, reducing the number of shipments to help manage freight cost.

Project Management

Experienced team members on hand to assist with ordering & execution of smallwares standards

- Assistance developing standardized order guides
- Managing smallwares for new stores, remodels & resets
- Experts in visual merchandising
- Free consultation services

HOW TO ORDER:

- Visit our website at www.hubert.com or call 1-800-543-7374
- Legacy Supervalu retailers use account # 809240
- Legacy UNFI retailers use account # 233779
- For convenient invoicing: Legacy Supervalu retailers on your UNFI Retailer statement. Legacy UNFI retailers HUBERT© invoice or credit card

Contact UNFI Equipment
Services for more information

You Can Count On Us!

Check Out the Perks of Our Partnership



UNFI custom website and mobile app – log in at partstown.com/unfi



The most in-stock parts on the planet – all real OEM, all the time



Same day shipping on all in-stock orders until 9PM ET Monday and until 4PM ET on Saturday for online air orders



Personalized customer service from a dedicated team



PLUS, custom pricing and shipping rates for the brands your kitchens use most

Shop These Top Brands (there are many more!)



Your Special Shipping Rates



25% OFF
Ground

25% OFF
2nd Day Air

25% OFF
Next Day Air

Contact Us Anytime!



Nicholetta Heliotis

PARTnership Builder
AKA: Director, Chain Partnerships
nheliotis@partstown.com



Partstown

The most in-stock, OEM foodservice equipment parts from hundreds of manufacturers.



- 3M
- A La Cart **M** 🔍
- Accurex **M**
- AccuTemp **🔥 M**
- Adamation **M**
- Alto-Shaam **🔥 ❄️**
- American Range **🔥 M**
- Amerikooler **❄️ M**
- Anets **🔥 M** 🔍
- Antunes **🔥 M** 🔍
- APW Wyott **🔥 M** 🔍
- Atlas Metal **❄️ M**
- Avtec **M** 🔍
- Bakers Pride **🔥 M** 🔍
- Beverage-Air **❄️**
- BevLes **🔥 M**
- BKI **🔥 M**
- Blakeslee **M**
- Blodgett **🔥 M** 🔍
- Bloomfield **🔥 M** 🔍
- Cadco **🔥 M**
- Carpigiani **M**
- Carter-Hoffmann **🔥 M**
- Cecilware **🔥 ❄️**
- Champion
- Cleveland **🔥 M**
- CMA Dish Machines
- Concordia Beverage Systems **M** 🔍
- Convotherm **🔥 M**
- Crathco **M**
- Cres Cor **🔥 M**
- Crown Steam **🔥 M**
- CrownTonka **❄️ M**

M Master Parts Distributor | ❄️ Cold Side | 🔥 Hot Side | 🔍 Serial Number Lookup

- Delfield **❄️ M**
- Dormont **M**
- DoughPro **🔥 M** 🔍
- Doyon **🔥 M**
- Duke **🔥** 🔍
- Electrolux Professional **🔥 ❄️ M**
- Elkay **M**
- Eurodib **🔥 M**
- Evo **🔥 M**
- Fagor **❄️ M**
- Federal Industries **M**
- Firex **🔥 M**
- Follett **❄️**
- Franke
- Frymaster **🔥 M**
- Garland **🔥 M**
- Gaylord M
- General A **M**
- Glastender **❄️** 🔍
- Globe **🔥 M**
- Grindmaster **M**
- Groen **🔥 M** 🔍
- Hammerall **M**
- Hatco **🔥 ❄️**
- Henny Penny **🔥** 🔍
- Hobart
- Holman **M** 🔍
- Hoshizaki **❄️ M**
- Hubbell Heaters **🔥 M**
- Husmann **❄️ M** 🔍
- Ice-O-Matic **❄️ M**
- Imperial Brown **❄️ M**
- Imperial **🔥 M**
- International Cold Storage **❄️ M**
- ITV Ice **❄️ M**
- Jackson **M**
- Jade Range **🔥 M**
- JBT **M** 🔍
- Jet Tech **M**
- JoeTap **M**
- Kelvinator Commercial **❄️ M**
- KOLD-DRAFT **❄️ M** 🔍
- Kolpak **❄️ M**
- Krowne Metal **M**
- Lancer **M**
- Lang **🔥 M**
- Lincoln **🔥 M**
- LoTemp Doors **❄️ M**
- MagiKitch'n **🔥 M** 🔍
- Manitowoc **❄️**
- Market Forge **🔥 M** 🔍
- Marsal **🔥 M** 🔍
- Master-Bilt **❄️ M**
- Maxx Cold **❄️ M**
- Maxx Ice **❄️ M**
- Meister Cook **🔥 M**
- Merco **🔥 M**
- Merrychef **🔥 M**
- Middleby Marshall **🔥 M**
- Montague **🔥 M**
- Multiplex **❄️**
- Nemco **M**
- Nieco **🔥 M**
- Nor-Lake **❄️ M** 🔍
- NU-VU **🔥 M**
- Ovention **🔥 M** 🔍
- Perfect Fry Company **🔥 M** 🔍
- Perlick **❄️ M** 🔍
- Picard Ovens **🔥 M**
- Pitco **🔥 M** 🔍
- Power Soak Systems **M** 🔍
- PrepRite **❄️ M**
- Prince Castle **🔥** 🔍
- Proluxe **🔥 M** 🔍
- Randell **❄️ M** 🔍
- RAM **M**
- RATIONAL **🔥**
- Robot Coupe **🔥**
- Rotisol **🔥 M**
- Royal Range **🔥 M**
- Salvajor **M**
- Sammic **M**
- Schaerer **M**
- Scotsman **❄️**
- Server **M**
- Silver King **❄️** 🔍
- Sipromac **M**
- Somerset **M**
- Southbend **🔥 M** 🔍
- Spaceman USA **M**
- Star **🔥 M** 🔍
- Stero
- T&S Brass
- Taylor **M**
- ThermalRite **❄️ M**
- Thermo-Kool **❄️ M**
- Thunderbird **M**
- Toastmaster **🔥 M** 🔍
- Town Food Service **🔥 M**
- Traulsen **❄️**
- Tri-Star **🔥 M** 🔍
- True **❄️**
- Turbo Air **❄️ M**
- TurboChef **🔥** 🔍
- Ultrafryer **🔥 M**
- UNIC **M**
- UNOX **🔥 M**
- Varimixer **M**
- Vulcan **🔥** 🔍
- WMF **M**
- Wells **🔥 M** 🔍
- Winston **🔥 M**
- Wilbur Curtis **M**
- Wunder-Bar **M**
- YORK
- Zesto **🔥 M**
- Zumex **M**

Right Part. Right Time. Every Time.®

View the full list at partstown.com/unfi/manufacturers

Your Guide to partstown.com/unfi

Partstown.com/unfi was designed with you in mind to make finding and buying the real OEM spare parts you need quick and easy. [Click here](#) to watch videos about several of our website innovations.

LOGIN

Choose **Login** to sign into your account. Enter your username and password. You can also request a login if you need it.

MY ACCOUNT

Once you're signed in, click **My Account** to access a catalog of your saved spare parts, equipment manuals, shipping addresses and view your order history.

FIND MANUALS

Enter your equipment information to find and download manuals.

TRACK YOUR ORDER

Enter your order or PO number along with your ZIP code to view order status.

SHOP BY KEYWORD

Enter a keyword or part number in the search bar to find the part you need.

SHOP BY MANUFACTURER

Choose your equipment manufacturer to browse available spare parts.

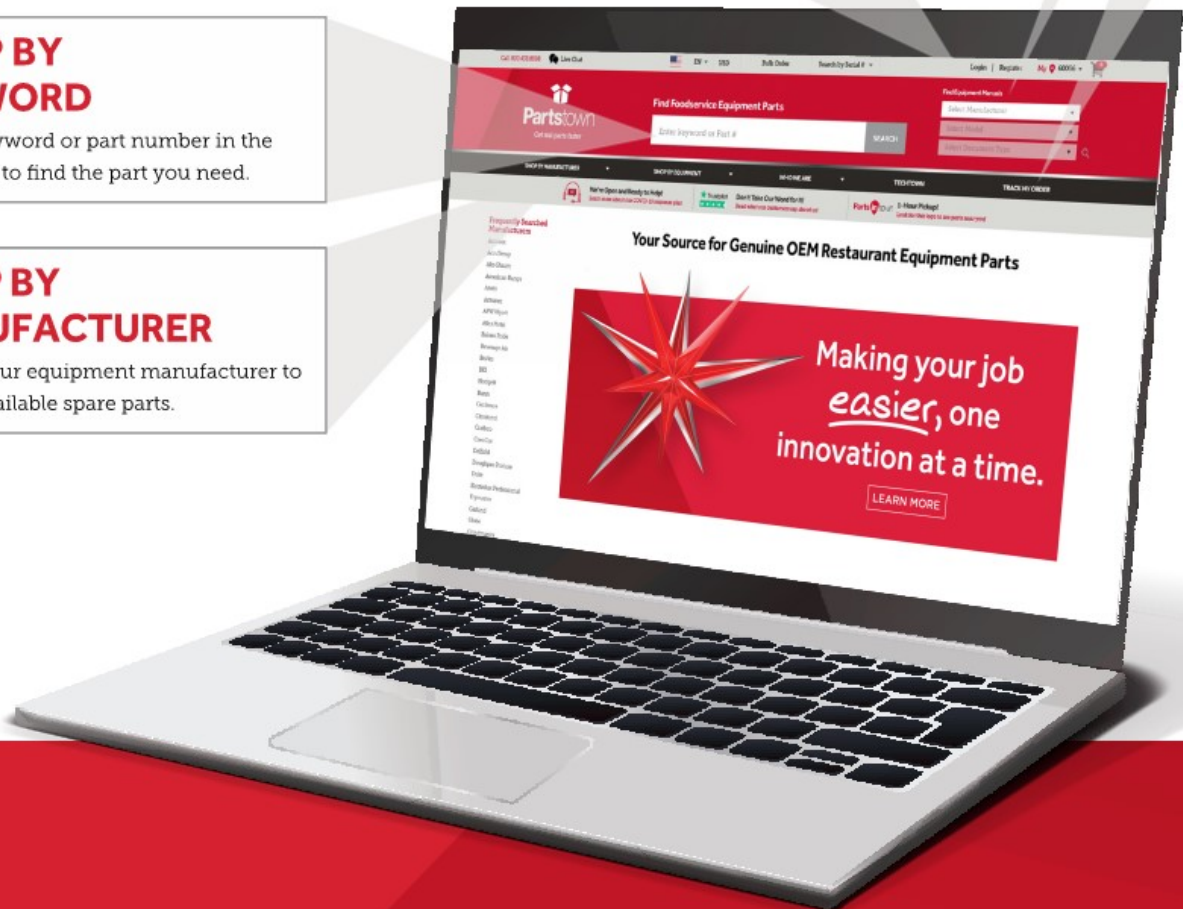



PartsTown

Get real parts faster

Innovations to Make Your Job Easier



SMART MANUALS

Thousands of our equipment manuals include hyperlinks that lead directly to product detail pages. [Learn More](#)



SERIAL NUMBER LOOKUP

Enter your equipment's serial number to see the exact list of parts and accessories needed, along with available warranty info. [Learn More](#)



PRODUCT DETAILS PAGE

Each product page features all of the equipment models that use that spare part. You can also refer to spare parts lists, images, manuals and diagrams for all of those models. [Learn More](#)



SAVE MULTIPLE SHOPPING CARTS

Create, save and share carts dedicated to different locations, jobs or kitchens. This is a great tool for technicians who need manager approval before purchasing spare parts. [Learn More](#)



QUICK ORDERING

From a product page, click "Quick Order" to add that spare part to you cart and proceed directly to checkout. Just verify your shipping address and payment info, then you're done. [Learn More](#)



BULK ORDERING

Use our online form to easily place large orders. Copy and paste up to 100 spare part numbers from your own document for quick and accurate ordering. [Learn More](#)



BETTER FOOD. BETTER FUTURE.

EQUIPMENT SERVICES

**11840 Valley View Road
Eden Prairie, MN 55344**