

EQUIPMENT SERVICES

2024 PRODUCT CATALOG





BACKROOM EQUIPMENT

Equipment Services



Inside this section:

Stainless Steel	4
Stainless Table Accessories	10
Material Handling	12
Utility Carts	14
Pallet Racking	19
Backroom Shelving	20
Janitorial	24
Traffic Doors	33
Balers & Compactors	35
Dock Equipment	36
Ladders	39
Janitorial & Backroom Smallwares Program	40
Walk-In Cooler & Freezer Boxes—see refrigeration section	N/A

Contact UNFI Equipment Services for member pricing & ordering
equipmentservices@unfi.com or 1.800.835.0165

Items in this catalog are subject to change & availability



SS TABLE

- 16 GA Stainless Steel
- Adjustable height bullet feet
- Custom sizing available upon request

ITEM NO	SIZE	DESCRIPTION
DTR-3036H35-SV	36" L X 30" W	SS TABLE, OPEN UNDERNEATH, NO BACKPLASH
DTR-3048H35-SV	48" L X 30" W	SS TABLE, OPEN UNDERNEATH, NO BACKPLASH
DTR-3060H35-SV	60" L X 30" W	SS TABLE, OPEN UNDERNEATH, NO BACKPLASH
DTR-3072H35-SV	72" L X 30" W	SS TABLE, OPEN UNDERNEATH, NO BACKPLASH
DTR-3084H35-SV	84" L X 30" W	SS TABLE, OPEN UNDERNEATH, NO BACKPLASH



SS TABLE W/ US

- 16 GA SS w/ undershelf
- Adjustable height bullet feet
- Custom sizing available upon request

ITEM NO	SIZE	DESCRIPTION
DTS-3036H35-SV	36" L X 30" W	SS TABLE, UNDERSHELF, NO BACKPLASH
DTS-3048H35-SV	48" L X 30" W	SS TABLE, UNDERSHELF, NO BACKPLASH
DTS-3060H35-SV	60" L X 30" W	SS TABLE, UNDERSHELF, NO BACKPLASH
DTS-3072H35-SV	72" L X 30" W	SS TABLE, UNDERSHELF, NO BACKPLASH



SS TABLE W/ BS

- 16 GA SS w/ backsplash
- Adjustable height bullet feet
- Custom sizing available upon request

ITEM NO	SIZE	DESCRIPTION
DTBB-3036H35-SV	36" X 30" W	SS TABLE, OPEN UNDERNEATH, BACKPLASH
DTBB-3048H35-SV	48" L X 30" W	SS TABLE, OPEN UNDERNEATH, BACKPLASH
DTBB-3060H35-SV	60" L X 30" W	SS TABLE, OPEN UNDERNEATH, BACKPLASH
DTBB-3072H35-SV	72" L X 30" W	SS TABLE, OPEN UNDERNEATH, BACKPLASH
DTBB-3084-SV	84" L X 30" W	SS TABLE, OPEN UNDERNEATH, BACKPLASH



SS TABLE W/ US & BS

- 16 GA SS w/ backsplash & undershelf
- Adjustable height bullet feet
- Custom sizing available upon request

ITEM NO	SIZE	DESCRIPTION
DTSBB-3036H35-SV	36" L X 30" W	SS TABLE, UNDERSHELF, BACKPLASH
DTSBB-3048H35-SV	48" L X 30" W	SS TABLE, UNDERSHELF, BACKPLASH
DTSBB-3060H35-SV	60" L X 30" W	SS TABLE, UNDERSHELF, BACKPLASH
DTSBB-3072H35-SV	72" L X 30" W	SS TABLE, UNDERSHELF, BACKPLASH
DTSBB-3084H35-SV	84" L X 30" W	SS TABLE, UNDERSHELF, BACKPLASH



POLY TOP TABLE

- Open underneath, no backslash
- 5/8" Thick polyethylene tops
- Custom sizing available upon request

ITEM NO	SIZE	DESCRIPTION
DPTR-3060H35-SV	60"L X 30"W	POLY TOP TABLE, OPEN UNDERNEATH, NO BACKSLASH
DPTR-3072H35-SV	72"L X 30"W	POLY TOP TABLE, OPEN UNDERNEATH, NO BACKSLASH



POLY TOP TABLE W/ US

- Includes SS undershelf
- 5/8" Thick polyethylene tops
- Custom sizing available upon request

ITEM NO	SIZE	DESCRIPTION
DPTS-3036H35-SV	36"L X 30"W	POLY TOP TABLE, UNDERSHELF, NO BACKSLASH
DPTS-3048H35-SV	48"L X 30"W	POLY TOP TABLE, UNDERSHELF, NO BACKSLASH
DPTS-3060H35-SV	60"L X 30"W	POLY TOP TABLE, UNDERSHELF, NO BACKSLASH
DPTS-3072H35-SV	72"L X 30"W	POLY TOP TABLE, UNDERSHELF, NO BACKSLASH
DPTS-3084H35-SV	84"L X 30"W	POLY TOP TABLE, UNDERSHELF, NO BACKSLASH



POLY TOP TABLE W/ BS

- 6"H backslash
- 5/8" Thick polyethylene tops
- Custom sizing available upon request

ITEM NO	SIZE	DESCRIPTION
DPTB-3036H35-ND-SV	36"L X 30"W	POLY TOP TABLE, OPEN UNDERNEATH, BACKSLASH
DPTB-3048H35-ND-SV	48"L X 30"W	POLY TOP TABLE, OPEN UNDERNEATH, BACKSLASH
DPTB-3060H35-ND-SV	60"L X 30"W	POLY TOP TABLE, OPEN UNDERNEATH, BACKSLASH
DPTB-3072H35-ND-SV	72"L X 30"W	POLY TOP TABLE, OPEN UNDERNEATH, BACKSLASH
DPTSBB-3084H35-Z-SV	84"L X 30"W	POLY TOP TABLE, OPEN UNDERNEATH, BACKSLASH



POLY TOP TABLE W/ US & BS

- Table w/ SS undershelf & backslash
- 5/8" Thick polyethylene tops
- Custom sizing available upon request

ITEM NO	SIZE	DESCRIPTION
DPTSBB-3036H35-SV	36"L X 30"W	POLY TOP TABLE, UNDERSHELF, BACKSLASH
DPTSBB-3048H35-ND-SV	48"L X 30"W	POLY TOP TABLE, UNDERSHELF, BACKSLASH
DPTSBB-3060H35-SV	60"L X 30"W	POLY TOP TABLE, UNDERSHELF, BACKSLASH
DPTSBB-3072H35-SV	72"L X 30"W	POLY TOP TABLE, UNDERSHELF, BACKSLASH
DPTSBB-3084H35-SV	84"L X 30"W	POLY TOP TABLE, UNDERSHELF, BACKSLASH



WOOD TOP TABLE - OPEN BAR

- Open underneath
- 1-3/4" Hard laminated maple wood top
- Custom sizing available upon request

ITEM NO	SIZE	DESCRIPTION
TSM-3648-W	48" L X 36" W	MAPLE TOP TABLE, OPEN BAR STYLE
TSM-3660-W	60" L X 36" W	MAPLE TOP TABLE, OPEN BAR STYLE
TSM-3672-W	72" L X 36" W	MAPLE TOP TABLE, OPEN BAR STYLE
TSM-3684-W	84" L X 36" W	MAPLE TOP TABLE, OPEN BAR STYLE



WOOD TOP TABLE W/ US

- Includes SS undershelf
- 1-3/4" Hard laminated maple wood top
- Custom sizing available upon request

ITEM NO	SIZE	DESCRIPTION
TSUM-3648-W	48" L X 36" W	MAPLE TOP TABLE, UNDERSHELF
TSUM-3660-W	60" L X 36" W	MAPLE TOP TABLE, UNDERSHELF
TSUM-3672-W	72" L X 36" W	MAPLE TOP TABLE, UNDERSHELF
TSUM-3684-W	84" L X 36" W	MAPLE TOP TABLE, UNDERSHELF

STAINLESS STEEL



SS TABLE W/ ENCLOSED BASE

- Sliding doors w/ backsplash
- Available with hinge or sliding doors
- Custom sizing available upon request

ITEM NO	SIZE	DESCRIPTION
STCT-BBD3036H36-E	36" L X 30" W	STAINLESS STEEL PREP TABLE W/ ENCLOSED CABINET BASE & BS
STCT-BBD3048H36-E	48" L X 30" W	STAINLESS STEEL PREP TABLE W/ ENCLOSED CABINET BASE & BS
STCT-BBD3060H36-E	60" L X 30" W	STAINLESS STEEL PREP TABLE W/ ENCLOSED CABINET BASE & BS
STCT-BBD3072H36-E	72" L X 30" W	STAINLESS STEEL PREP TABLE W/ ENCLOSED CABINET BASE & BS



ONE COMP SINK

- Single comp sink no drainboards
- Includes all sink hardware
- Custom sizing available upon request

ITEM NO	SIZE	DESCRIPTION
WS-DIS-ME-1818DP15-SVKT	18" x 18" x 12" D TUB	ONE COMPARTMENT SINK, W/O DRAINBOARDS



ONE COMP SINK W/ DB

- Single drainboard right or left
- Includes all sink hardware
- Custom sizing available upon request

ITEM NO	SIZE	DESCRIPTION
WS1T1818RD18-SVKT	18" x 18" x 12"D TUB, (1) 18" DB	ONE COMPARTMENT SINK, RIGHT-HAND DRAINBOARD
WS1T1818LD18-SVKT	18" x 18" x 12"D TUB, (1) 18" DB	ONE COMPARTMENT SINK, LEFT-HAND DRAINBOARD
WS1T1824RD18-SVKT	18" X 24" X 12"D TUB, (1) 18"DB	ONE COMPARTMENT SINK, RIGHT-HAND DRAINBOARD
WS1T1824LD18-SVKT	18" X 24" X 12"D TUB, (1) 18"DB	ONE COMPARTMENT SINK, LEFT-HAND DRAINBOARD
WS1T2424RD24-SVKT	24" X 24" X 12"D TUB, (1) 24" DB	ONE COMPARTMENT SINK, RIGHT-HAND DRAINBOARD
WS1T2424LD24-SVKT	24" X 24" X 12"D TUB, (1) 24" DB	ONE COMPARTMENT SINK, LEFT-HAND DRAINBOARD



ONE COMP SINK W/ DBS

- Double drainboard on right and left
- Includes all sink hardware
- Custom sizing available upon request

ITEM NO	SIZE	DESCRIPTION
S1-1818-18-W	18" x 18" x 12"D TUB, (2) 18" DBS	ONE COMPARTMENT SINK W/ DRAINBOARDS LEFT & RIGHT
S1-1824-18-W	18" x 24" x 12"D TUB, (2) 18" DBS	ONE COMPARTMENT SINK W/ DRAINBOARDS LEFT & RIGHT
S1-1824-24-W	18" X 24" X 12"D TUB, (2) 24" DBS	ONE COMPARTMENT SINK W/ DRAINBOARDS LEFT & RIGHT
S1-2424-18-W	24" X 24" X 12"D TUB, (2) 18" DBS	ONE COMPARTMENT SINK W/ DRAINBOARDS LEFT & RIGHT
S1-2424-24-W	24" X 24" X 12"D TUB, (2) 24" DBS	ONE COMPARTMENT SINK W/ DRAINBOARDS LEFT & RIGHT

STAINLESS STEEL



TWO COMP SINK

- Double sinks w/o drainboards
- Includes all sink hardware
- Custom sizing available upon request

ITEM NO	SIZE	DESCRIPTION
S2-1818-W	18" X 18" X 12"D TUBS	TWO COMPARTMENT SINK W/O DRAINBOARDS
S2-1620-W	16" X 20" X 12"D TUBS	TWO COMPARTMENT SINK W/O DRAINBOARDS
S2-1824-W	18" X 24" X 12"D TUBS	TWO COMPARTMENT SINK W/O DRAINBOARDS
S2-2020-W	20" X 20" X 12"D TUBS	TWO COMPARTMENT SINK W/O DRAINBOARDS



TWO COMP SINK W/ DBS

- Single drainboard right or left
- Includes all sink hardware
- Custom sizing available upon request

ITEM NO	SIZE	DESCRIPTION
WS2T1824LD18-SS-SVKT	18" X 24" X 12"D TUBS, (1) 18"DB	TWO COMPARTMENT SINK, LEFT-HAND DRAINBOARD



TWO COMP SINK W/ DBS

- Double drainboard on right and left
- Includes all sink hardware
- Custom sizing available upon request

ITEM NO	SIZE	DESCRIPTION
WS2T1824-S5-SVKT	18" X 24" X 12"D TUBS, (2) 24" DBS	ONE COMPARTMENT SINK W/ DRAINBOARDS LEFT & RIGHT



THREE COMP SINK

- Three comp sink w/o drainboards
- Includes all sink hardware
- Custom sizing available upon request

ITEM NO	SIZE	DESCRIPTION
WS3T1818SS-14-UGKT	18" x 18" x 12" D TUBS	THREE COMPARTMENT SINK W/O DRAINBOARDS



THREE COMP SINK W/ DBS

- Single drainboard right or left
- Includes all sink hardware
- Custom sizing available upon request

ITEM NO	SIZE	DESCRIPTION
WS3T2424LD24-14D-2FH-SVKT	24" X 24" X 12" D TUBS, (1) 24" DB	THREE COMPARTMENT SINK, LEFT-HAND DRAINBOARD



THREE COMP SINK W/ DBS

- Double drainboard on right and left
- Includes all sink hardware
- Custom sizing available upon request

ITEM NO	SIZE	DESCRIPTION
S3-1818-18-W	18" x 18" x 12" D TUBS, (2) 18" DBS	THREE COMPARTMENT SINK W/ DRAINBOARDS LEFT & RIGHT
S3-1824-18-W	18" x 24" x 12" D TUBS, (2) 18" DBS	THREE COMPARTMENT SINK W/ DRAINBOARDS LEFT & RIGHT
S3-1824-24-W	18" X 24" X 12" D TUBS, (2) 24" DBS	THREE COMPARTMENT SINK W/ DRAINBOARDS LEFT & RIGHT
S3-2424-18-W	24" X 24" X 12" D TUBS, (2) 18" DBS	THREE COMPARTMENT SINK W/ DRAINBOARDS LEFT & RIGHT
S3-2424-24-W	24" X 24" X 12" D TUBS, (2) 24" DBS	THREE COMPARTMENT SINK W/ DRAINBOARDS LEFT & RIGHT



WALL MOUNTED HAND SINK

- Side and back splash
- Has all sink hardware and knee valves
- Optional side splashes available

ITEM NO	SIZE	DESCRIPTION
WS-HS-1616KV-2SS-SVKT	16" X 16" X 10"D BOWL	WALL MOUNT HAND SINK W/ OPTIONAL SIDE SPLASHES
WS-HS-1410KV-2SS-KT	14" X 10" X 5"D BOWL	WALL MOUNT HAND SINK W/ OPTIONAL SIDE SPLASHES



PEDESTAL HAND SINK

- includes backsplash
- Has all sink hardware and foot pedals
- Optional side splashes available

ITEM NO	SIZE	DESCRIPTION
WHPS1616-KT	16" X 16" X 10"D BOWL	PEDESTAL STYLE HAND SINK W/ FOOT PEDALS



ONE COMP DROP IN SINK

- Side and back splash
- Includes all sink hardware
- More sizes and special features available upon request

ITEM NO	SIZE	DESCRIPTION
DI-1-10	14"L X 10"W X 10"D BOWL	ONE COMPARTMENT DROP IN SINK
DI-1-10SP	14"L X 10"W X 10"D BOWL	ONE COMPARTMENT DROP IN SINK W/ SIDE SPLASH
DI-1-168	14"L X 16"W X 8"D BOWL	ONE COMPARTMENT DROP IN SINK
DI-1-2012	16"L X 20"W X 12"D BOWL	ONE COMPARTMENT DROP IN SINK W/ DEEP BOWL



TWO COMP DROP IN SINK

- Side and back splash
- Includes all sink hardware
- More sizes and special features available upon request

ITEM NO	SIZE	DESCRIPTION
DI-2-10	14"L X 10"W X 10"D BOWL	TWO COMPARTMENT DROP IN SINK
DI-2-1410	16"L X 14"W X 10"D	TWO COMPARTMENT DROP IN SINK
DI-2-2012	16"L X 20"W X 12"D BOWL	TWO COMPARTMENT DROP IN SINK



BOAT RACK

- Aluminum construction
- Compatible w/ all SS tables
- Wall mount or table mount options available

ITEM NO	SIZE	DESCRIPTION
SSBR-1236-W	36" L X 12" D	WALL MOUNTED BOAT RACK
SSBR-1248-W	48" L X 12" D	WALL MOUNTED BOAT RACK
SSBR-1260-W	60" L X 12" D	WALL MOUNTED BOAT RACK
SSBR-1272-W	72" L X 12" D	WALL MOUNTED BOAT RACK



POT RACK W/ SHELF

- Stainless Steel construction
- Wall mounted
- Shelf above hooks

ITEM NO	SIZE	DESCRIPTION
SSWMSH124	48" L X 12" D	POT RACK W/ SHELF
SSWMSH125	60" L X 12" D	POT RACK W/ SHELF
SSWMSH126	72" L X 12" D	POT RACK W/ SHELF

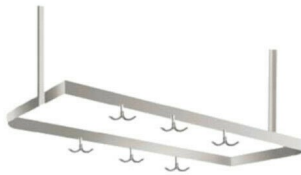

HANGING POT RACK

- Stainless Steel construction
- Ceiling mounted
- Includes 18 pot hooks

ITEM NO	SIZE	DESCRIPTION
SSCMR-3016	36" L	STAINLESS STEEL CEILING MOUNT POT RACK
SSCMR-4816	48" L	STAINLESS STEEL CEILING MOUNT POT RACK
SSCMR-6016	60" L	STAINLESS STEEL CEILING MOUNT POT RACK
SSCMR-7216	72" L	STAINLESS STEEL CEILING MOUNT POT RACK

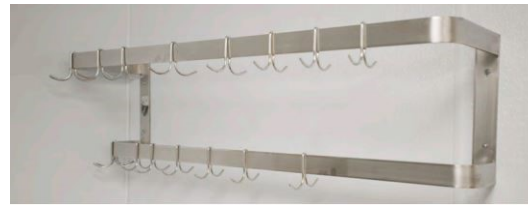

WALL MOUNT POT RACK

- Stainless Steel construction
- Single and double racks available
- Includes pot hooks, qty depending on size/style

ITEM NO	SIZE	DESCRIPTION
SSWMR-3016-S	36" L	SINGLE STAINLESS STEEL WALL MOUNT POT RACK
SSWMR-4816-S	48" L	SINGLE STAINLESS STEEL WALL MOUNT POT RACK
SSWMR-6016-S	60" L	SINGLE STAINLESS STEEL WALL MOUNT POT RACK
SSWMR-7216-S	72" L	SINGLE STAINLESS STEEL WALL MOUNT POT RACK
SSWMR-3016-D	36" L	DOUBLE STAINLESS STEEL WALL MOUNT POT RACK
SSWMR-4816-D	48" L	DOUBLE STAINLESS STEEL WALL MOUNT POT RACK
SSWMR-6016-D	60" L	DOUBLE STAINLESS STEEL WALL MOUNT POT RACK
SSWMR-7216-D	72" L	DOUBLE STAINLESS STEEL WALL MOUNT POT RACK



WALL MOUNT SHELF

- Stainless Steel construction
- Additional sizes available upon request
- Includes 2-4 brackets depending on size

ITEM NO	SIZE	DESCRIPTION
SSWMSH123	36"L X 12"W	STAINLESS STEEL WALL MOUNT SHELF
SSWMS124	48"L X 12"W	STAINLESS STEEL WALL MOUNT SHELF
SSWMS125	60"L X 12"W	STAINLESS STEEL WALL MOUNT SHELF
SSWMS126	72"L X 12"W	STAINLESS STEEL WALL MOUNT SHELF
SSWMS153	36"L X 15"W	STAINLESS STEEL WALL MOUNT SHELF
SSWMS154	48"L X 15"W	STAINLESS STEEL WALL MOUNT SHELF
SSWMS155	60"L X 15"W	STAINLESS STEEL WALL MOUNT SHELF
SSWMS156	72"L X 15"W	STAINLESS STEEL WALL MOUNT SHELF



HAND PALLET JACK

- Manual power
- 5,000 pound capacity
- Heavy duty one piece formed forks for maximum durability

ITEM NO	SIZE	DESCRIPTION
PTH502736	36" L X 27" W FORKS	MANUAL PALLET JACK
PTH502742	42" L X 27" W FORKS	MANUAL PALLET JACK
PTH502748	48" L X 27" W FORKS	MANUAL PALLET JACK
PTH502754	54" L X 27" W FORKS	MANUAL PALLET JACK
PTH502760	60" L X 27" W FORKS	MANUAL PALLET JACK



ELECTRIC PALLET JACK

- Electric power
- 4,500 pound capacity
- Nominal fork lengths of 36/42/48 inches

ITEM NO	SIZE	DESCRIPTION
WP3035-45	42" L X 28" W FORKS	ELECTRIC PALLET JACK W/ MF BATTERY
WP3035-45-WC	42" L X 28" W FORKS	ELECTRIC PALLET JACK W/ WC BATTERY



WORK ASSIST VEHICLE - WAV SERIES

- 24 Volt electric power
- 118" platform height
- Minimum turn radius of 47.5"

ITEM NO	SIZE	DESCRIPTION
WAV60-118	60" L X 27" W	WAV WORK ASSIST VEHICLE



NARROW AISLE REACH TRUCK

- Specs vary based on customer needs
- Can handle up to 4000 pounds
- Ergonomic construction for ease of operation

ITEM NO	SIZE	DESCRIPTION
RR5715-35	42" W, 198" H, 42" W FORKS	RIDER REACH TRUCK 3500# CAP
RR5715-40	42" W, 198" H, 42" W FORKS	RIDER REACH TRUCK 4000# CAP



WALKIE STRADDLE STACKER

- Load capacities up to 4000 pounds
- Lift height up to 192"
- Includes batteries, charger and load backrest

ITEM NO	SIZE	DESCRIPTION
SX3000-30TT154	42" FORKS, 128"-192"LH	STRADDLE WALKIE STACKER 3000LB CAP
ST3000-25TT154	42" FORKS, 128"-168"LH	STRADDLE WALKIE STACKER 2500LB CAP

MATERIAL HANDLING



BANQUET CARTS

- Aluminum or stainless steel
- Available in 3, 4 and 5 shelf options
- Maneuvers on (2) rigid and (2) swivel polyurethane wheels

ITEM NO	SIZE	DESCRIPTION
BNQT-3	60"L X 28"W	ALUMINUM BANQUET CART W/ (3) SHELVES
BNQT-4	60"L X 28"W	ALUMINUM BANQUET CART W/ (4) SHELVES
BNQT-5	60"L X 28"W	ALUMINUM BANQUET CART W/ (5) SHELVES
BNQT-3-SS	60"L X 28"W	STAINLESS STEEL BANQUET CART W/ (3) SHELVES
BNQT-4-SS	60"L X 28"W	STAINLESS STEEL BANQUET CART W/ (4) SHELVES
BNQT-5-SS	60"L X 28"W	STAINLESS STEEL BANQUET CART W/ (5) SHELVES



UTILITY CART

- Medium duty stainless steel construction
- Available in 2 or 3 shelves
- maneuvers on 5" polyurethane plate swivel stem casters

ITEM NO	SIZE	DESCRIPTION
SSUC-2-1832/1H/45H	37"L X 18"W X 44"H	STAINLESS STEEL UTILITY CART W/ (2) SHELVES
SSUC-3-1832/1H/45H	37"L X 18"W X 44"H	STAINLESS STEEL UTILITY CART W/ (3) SHELVES
SSUC-2-2133/1H/45H	38"L X 21"W X 44"H	STAINLESS STEEL UTILITY CART W/ (2) SHELVES
SSUC-3-2133/1H/45H	38"L X 21"W X 44"H	STAINLESS STEEL UTILITY CART W/ (3) SHELVES



GALVANIZED DOLLY

- Welded galvanized steel construction
- Sheet pans or stack & nest containers
- Maneuvers on (2) swivel plate casters and (2) rubber rigid plate casters

ITEM NO	SIZE	DESCRIPTION
DSN-2618	26"L X 18"W	GALVANIZED STEEL DOLLY
SN-2618	26"L X 19"W	GRAY POLYETHYLENE CONTAINER
LID-2618	27"L X 16"W	GRAY POLYETHYLENE LID FOR CONTAINER



TUBULAR DOLLY

- Heavy duty aluminum construction
- Rust proof square tubing
- Maneuvers on (2) rigid and (2) swivel polyolefin plate casters

ITEM NO	SIZE	DESCRIPTION
TD-2428	28"L X 27"W	ALUMINUM TUBULAR DOLLY



SANI STOCK CART

- Heavy duty aluminum construction
- T-bar shelves provide extra strength
- Maneuvers on (2) swivel plate and (2) rigid plate casters

ITEM NO	SIZE	DESCRIPTION
TBST-1837	39"L X 18"W X 37"H	ALUMINUM SANI STOCK CART

Custom**Color** It.



DUNNAGE RACK

- Aluminum tube construction
- 12"H above the floor
- Available in several different size options

ITEM NO	SIZE	DESCRIPTION
ALSQ-3-1220	36"L X 20"W X 12"H	ALUMINUM DUNNAGE RACK
ALSQ-4-1220	48"L X 20"W X 12"H	ALUMINUM DUNNAGE RACK
ALSQ-5-1220	60"L X 20"W X 12"H	ALUMINUM DUNNAGE RACK
ALSQ-3-1224	36"L X 24"W X 12"H	ALUMINUM DUNNAGE RACK
ALSQ-4-1224	48"L X 24"W X 12"H	ALUMINUM DUNNAGE RACK
ALSQ-5-1224	60"L X 24"W X 12"H	ALUMINUM DUNNAGE RACK



PLASTIC DUNNAGE RACK

- One piece plastic construction
- 12"H above the floor
- Available in gray or black colors

ITEM NO	SIZE	DESCRIPTION
PLSQ-3-1222-GY	36"L X 22"W X 12"H	GRAY PLASTIC DUNNAGE RACK
PLSQ-4-1222-GY	48"L X 22"W X 12"H	GRAY PLASTIC DUNNAGE RACK
PLSQ-5-1222-GY	60"L X 22"W X 12"H	GRAY PLASTIC DUNNAGE RACK
DPLSQ-3-1222-BK	36"L X 22"W X 12"H	BLACK PLASTIC DUNNAGE RACK
DPLSQ-4-1222-BK	48"L X 22"W X 12"H	BLACK PLASTIC DUNNAGE RACK
DPLSQ-5-1222-BK	60"L X 22"W X 12"H	BLACK PLASTIC DUNNAGE RACK



ALUMINUM LUG CART

- Aluminum or stainless steel
- 10" spacing between runners
- Lugs sold separately see next item

ITEM NO	SIZE	DESCRIPTION
AL-L-1	25"L X 16"W X 19"H	ALUMINUM LUG CART, (1) LUG CAPACITY
AL-L-2	28"L X 16"W X 35"H	ALUMINUM LUG CART, (2) LUG CAPACITY
AL-L-3	27"L X 19"W X 41"H	ALUMINUM LUG CART, (3) LUG CAPACITY
AL-L-6	27"L X 19"W X 71"H	ALUMINUM LUG CART (6) LUG CAPACITY
SS-L-1	25"L X 16"W X 19"H	STAINLESS STEEL LUG CART (1) LUG CAPACITY
SS-L-2	28"L X 16"W X 35"H	STAINLESS STEEL LUG CART (2) LUG CAPACITY
SS-L-3	27"L X 19"W X 41"H	STAINLESS STEEL LUG CART (3) LUG CAPACITY
SS-L-5	27"L X 19"W X 71"H	STAINLESS STEEL LUG CART (5) LUG CAPACITY



LUGS

- Polyethylene will not rust or dent
- 1.3 cu. Ft capacity, holds up to 100 lbs
- Available in gray, white, red and blue

ITEM NO	SIZE	DESCRIPTION
WHPL-8GY-WH	25"L X 16"W X 8"H	GRAY LUG
WHPL-8WH	25"L X 16"W X 8"H	WHITE LUG
WHPL-8RD-RC	25"L X 16"W X 8"H	RED LUG
WHPL-8BL-RC	25"L X 16"W X 8"H	BLUE LUG
WHPL-8LID-GY	25" L X 16" W	GRAY LUG LID
WHPL-8LID-WH	25" L X 16" W	WHITE LUG LID



STEEL DECK U-BOAT

- Anti-skid diamond plate steel deck
- Includes (2) high end removeable handles
- maneuvers on (2) stationary cent load

ITEM NO	SIZE	DESCRIPTION
300-48D-PU	51"L X 16"W X 61"H	DIAMOND STEEL DECK U-BOAT
300-60D-PU	63"L X 16"W X 61"H	DIAMOND STEEL DECK U-BOAT



PLASTIC DECK U-BOAT

- Light weight, gray plastic deck
- All welded steel end handles and frame
- Narrow 18" w designed for busy aisles

ITEM NO	SIZE	DESCRIPTION
P300-60	60"L X 18 X 63"H	DIAMOND STEEL DECK U-BOAT



STEEL STOCK CART

- Square, heavy duty steel
- ideal for narrow aisles
- Green powder coated finish, other colors available upon request

ITEM NO	SIZE	DESCRIPTION
SC-1836-6W-GN	43"L X 18"W X 40"H	GREEN STEEL UTILITY STOCK CART
SC-1848-6W-GN	55"L X 18"W X 40"H	GREEN STEEL UTILITY STOCK CART



ALUMINUM STOCK CART

- All welded aluminum cart
- Two shelves
- maneuvers on (2) swivel and (2) rigid casters

ITEM NO	SIZE	DESCRIPTION
ALUC-2-2036-36H	42"L X 20"W X 36"H	ALUMINUM UTILITY STOCK CART



FLAT BED UTILITY CART

- All welded, tubular steel construction
- Aluminum powder coated finish
- maneuvers on (2) stationary center wheels & (4) swivel end casters

ITEM NO	SIZE	DESCRIPTION
SC1652T	42"L X 16"W X 36"H	FLAT BED STEEL STOCK CART



STEEL HAND TRUCKS

- Steel or standard tubular construction
- Heavy duty all welded reinforced plates
- Available w/ either mold-on rubber or semi pneumatic wheels

ITEM NO	SIZE	DESCRIPTION
508SP	19"L X 20"W X 47"H	STEEL HAND TRUCK W. SEMI-PNEUMATIC
99MR	19"L X 20"W X 47"H	TUBULAR HAND TRUCK W/ MOLD ON RUBBER
99SP	19"L X 20"W X 47"H	TUBULAR HAND TRUCK W/ SEMI PNEUMATIC



WET PRODUCE CART

- Galvanized steel or aluminum
- Top pan is removable and reversible
- Maneuvers on (2) swivel and (2) rigid casters

ITEM NO	SIZE	DESCRIPTION
WPT-2340	42"L X 25"W X 36"H	GALVANIZED STEEL WET PRODUCE CART
WPT-2340-AL-WM	42"L X 25"W X 36"H	ALUMINUM WET PRODUCE CART



ALUMINUM PLATTER CART

- Aluminum or stainless steel
- Trays not included
- Additional tray sizes and capacities available upon request

ITEM NO	SIZE	DESCRIPTION
AL-1010	26"L X 13"W X 67"H	ALUMINUM PLATTER CART, 10 - 10" TRAY CAPACITY
AL-1210	26"L X 15"W X 67"H	ALUMINUM PLATTER CART, 10 - 12" TRAY CAPACITY
AL-1810B	26"L X 20"W X 67"H	ALUMINUM PLATTER CART, 10 - 18" TRAY CAPACITY
AL-1012	26"L X 13"W X 67"H	ALUMINUM PLATTER CART, 12 - 12" TRAY CAPACITY
AL-1212	26"L X 15"W X 67"H	ALUMINUM PLATTER CART, 12 - 18" TRAY CAPACITY
AL-1812B	26"L X 20"W X 67"H	ALUMINUM PLATTER CART, 12 - 18" TRAY CAPACITY



PLATTERS AND TRAYS

- Constructed super hi-impact polystyrene
- Designed with all smooth surfaces
- Compatible with platter carts 18" tray design

ITEM NO	SIZE	DESCRIPTION
WHP-1826WH	26"L X 18"W	POLYSTYRENE PLATTER TRAY, WHITE
WHP-1826GABS	26"L X 18"W	POLYSTYRENE PLATTER TRAY, GREEN
AP-1826	26"L X 18"W	POLYSTYRENE PLATTER TRAY, ALUMINUM



SANI-PLATTERS

- Constructed super hi-impact polystyrene
- Designed with extra ribbing for rigidity
- Compatible with platter carts 10" and 12" tray design

ITEM NO	SIZE	DESCRIPTION
WHP-1030	30"L X 10"	POLYSTYRENE SANI PLATTER
WHP-1224	24"L X 12"W	POLYSTYRENE SANI PLATTER
AP-1826	30"L X 12"W	POLYSTYRENE SANI PLATTER

PALLET RACKING FOR ALL YOUR GROCERY STORE NEEDS

Standard 3-Tier (Hand Stack)

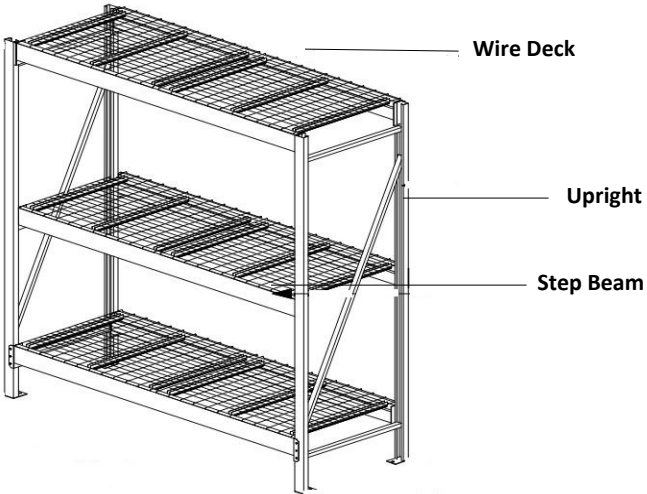

Standard 2-Tier (Pallet Storage)

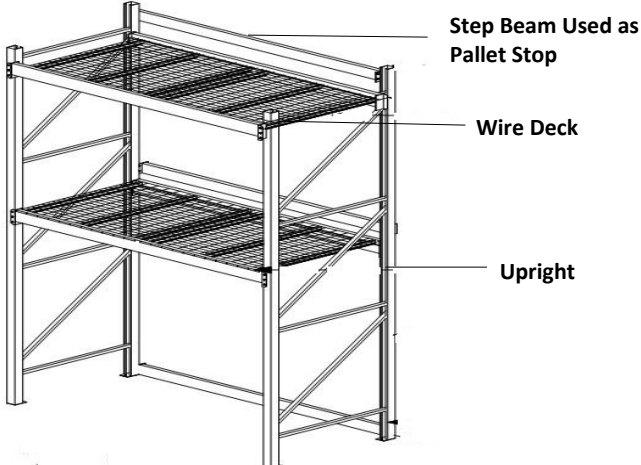

Standard 1-Tier (Pallet Storage)

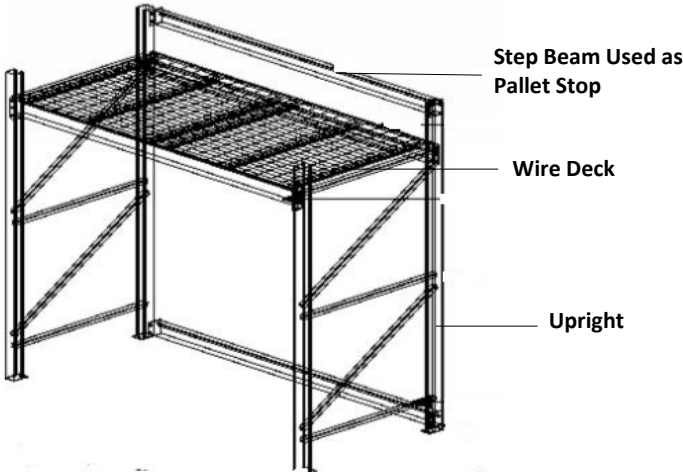

Typical Grocery Area's That Utilize Pallet Racking:

- **Backroom:** Receiving, Storage, Janitor and Bakery Rooms
- **Coolers:** Deli, Dairy, Meat, Produce, Seafood, Beverage Coolers & Caves
- **Freezers:** Grocery, Meat and Seafood Freezers

***Painted and Galvanized finishes available*

Standard Pallet Rack Components:

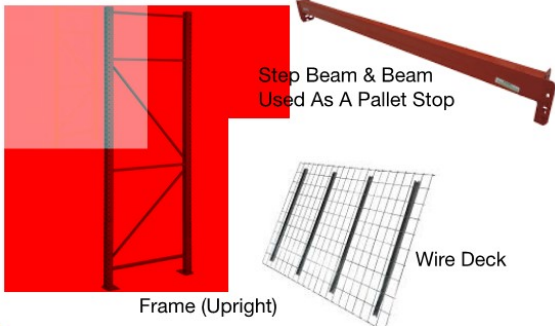



CANTILEVER SHELVING

- Heavy duty aluminum construction
- Comes in starter and add on kits
- Additional sizes available upon request

ITEM NO	SIZE	DESCRIPTION
SCAS-2436-3-SU	36"L X 24"W	CANTILEVER STARTER KIT W/ (3) SHELVES
SCAS-2436-3-AU	36"L X 24"W	CANTILEVER ADD-ON KIT W/ (3) SHELVES
SCAS-2448-3-SU	48"L X 24"W	CANTILEVER STARTER KIT W/ (3) SHELVES
SCAS-2448-3-AU	48"L X 24"W	CANTILEVER ADD-ON KIT W/ (3) SHELVES
SCAS-2460-3-SU	60"L X 24"W	CANTILEVER STARTER KIT W/ (3) SHELVES
SCAS-2460-3-AU	60"L X 24"W	CANTILEVER ADD-ON KIT W/ (3) SHELVES



SHELVING BLACK EPOXY

- Kit includes (4) shelves and posts
- Used for wet and dry applications
- Post and shelves come in a variety of different sizes

ITEM NO	SIZE	DESCRIPTION
18367B	36"L X 18"W X 74"H	WIRE SHELVING KIT BLACK EPOXY
18487B	48"L X 18"W X 74"H	WIRE SHELVING KIT BLACK EPOXY
18607B	60"L X 18"W X 74"H	WIRE SHELVING KIT BLACK EPOXY
24367B	36"L X 24"W X 74"H	WIRE SHELVING KIT BLACK EPOXY
24487B	48"L X 24"W X 74"H	WIRE SHELVING KIT BLACK EPOXY
24607B	60"L X 24"W X 74"H	WIRE SHELVING KIT BLACK EPOXY



SHELVING SILVER EPOXY

- Kit includes (4) shelves and posts
- Used for wet and dry applications
- Post and shelves come in a variety of different sizes

ITEM NO	SIZE	DESCRIPTION
18367EP	36"L X 18"W X 74"H	WIRE SHELVING KIT SILVER EPOXY
18487EP	48"L X 18"W X 74"H	WIRE SHELVING KIT SILVER EPOXY
18607EP	60"L X 18"W X 74"H	WIRE SHELVING KIT SILVER EPOXY
24367EP	36"L X 24"W X 74"H	WIRE SHELVING KIT SILVER EPOXY
24487EP	48"L X 24"W X 74"H	WIRE SHELVING KIT SILVER EPOXY
24607EP	60"L X 24"W X 74"H	WIRE SHELVING KIT SILVER EPOXY



SHELVY POLY-Z-BRITE

- Kit includes (4) shelves and posts
- Antimicrobial powder-epoxy finish
- Post and shelves come in a variety of different sizes

ITEM NO	SIZE	DESCRIPTION
18367Z	36"L X 18"W X 74"H	WIRE SHELVING KIT POLY-Z-BRITE
18487Z	48"L X 18"W X 74"H	WIRE SHELVING KIT POLY-Z-BRITE
18607Z	60"L X 18"W X 74"H	WIRE SHELVING KIT POLY-Z-BRITE
24367Z	36"L X 24"W X 74"H	WIRE SHELVING KIT POLY-Z-BRITE
24487Z	48"L X 24"W X 74"H	WIRE SHELVING KIT POLY-Z-BRITE
24607Z	60"L X 24"W X 74"H	WIRE SHELVING KIT POLY-Z-BRITE



SHELVING POLY GREEN

- Kit includes (4) shelves and posts
- Antimicrobial powder-epoxy finish
- Post and shelves come in a variety of different sizes

ITEM NO	SIZE	DESCRIPTION
18367G	36"L X 18"W X 74"H	WIRE SHELVING KIT POLY GREEN
18487G	48"L X 18"W X 74"H	WIRE SHELVING KIT POLY GREEN
18607G	60"L X 18"W X 74"H	WIRE SHELVING KIT POLY GREEN
24367G	36"L X 24"W X 74"H	WIRE SHELVING KIT POLY GREEN
24487G	48"L X 24"W X 74"H	WIRE SHELVING KIT POLY GREEN
24607G	60"L X 24"W X 74"H	WIRE SHELVING KIT POLY GREEN



WIRE SHELVING CHROME

- Kit includes (4) shelves and posts
- Chrome finish for dry application only
- Post and shelves come in a variety of different sizes

ITEM NO	SIZE	DESCRIPTION
18367C	36"L X 18"W X 74"H	WIRE SHELVING KIT CHROME
18487C	48"L X 18"W X 74"H	WIRE SHELVING KIT CHROME
18607C	60"L X 18"W X 74"H	WIRE SHELVING KIT CHROME
24367C	36"L X 24"W X 74"H	WIRE SHELVING KIT CHROME
24487C	48"L X 24"W X 74"H	WIRE SHELVING KIT CHROME
24607C	60"L X 24"W X 74"H	WIRE SHELVING KIT CHROME



WIRE SHELVING NEXELON

- Kit includes (4) shelves and posts
- Lifetime warranty
- Post and shelves come in a variety of different sizes

ITEM NO	SIZE	DESCRIPTION
PM18367N	36"L X 18"W X 74"H	WIRE SHELVING KIT NEXELON
PM18487GN	48"L X 18"W X 74"H	WIRE SHELVING KIT NEXELON
PM18607N	60"L X 18"W X 74"H	WIRE SHELVING KIT NEXELON
PM24367GN	36"L X 24"W X 74"H	WIRE SHELVING KIT NEXELON
PM24487GN	48"L X 24"W X 74"H	WIRE SHELVING KIT NEXELON
PM24607GN	60"L X 24"W X 74"H	WIRE SHELVING KIT NEXELON



E-Z ADJUSTER SHELVING

- Kit includes (4) shelves and posts
- Available in Chrome or Poly-Z-Brite
- Post and shelves come in a variety of different sizes

ITEM NO	SIZE	DESCRIPTION
1836AC	36"L X 18"W	CHROME E-Z ADJUSTER SHELF KIT
1848AC	48"L X 18"W	CHROME E-Z ADJUSTER SHELF KIT
1860AC	60"L X 18"W	CHROME E-Z ADJUSTER SHELF KIT
2448AC	48"L X 24"W	CHROME E-Z ADJUSTER SHELF KIT
2460AC	60"L X 24"W	CHROME E-Z ADJUSTER SHELF KIT
1836AZ	36"L X 18"W	POLY-Z-BRITE E-Z ADJUSTER SHELF KIT
1848AZ	48"L X 18"W	POLY-Z-BRITE E-Z ADJUSTER SHELF KIT
1860AZ	60"L X 18"W	POLY-Z-BRITE E-Z ADJUSTER SHELF KIT
2448AZ	48"L X 24"W	POLY-Z-BRITE E-Z ADJUSTER SHELF KIT
2460AZ	60"L X 24"W	POLY-Z-BRITE E-Z ADJUSTER SHELF KIT



SHELVING STAINLESS

- Kit includes (4) shelves and posts
- Ideal for wet and dry application
- Post and shelves come in a variety of different sizes

ITEM NO	SIZE	DESCRIPTION
18367S	36"L X 18"W X 74"H	WIRE SHELVING KIT STAINLESS STEEL
18487S	48"L X 18"W X 74"H	WIRE SHELVING KIT STAINLESS STEEL
18607S	60"L X 18"W X 74"H	WIRE SHELVING KIT STAINLESS STEEL
24367S	36"L X 24"W X 74"H	WIRE SHELVING KIT STAINLESS STEEL
24487S	48"L X 24"W X 74"H	WIRE SHELVING KIT STAINLESS STEEL
24607S	60"L X 24"W X 74"H	WIRE SHELVING KIT STAINLESS STEEL



ADJUSTABLE POST KIT

- Brackets come in single and double
- Chrome finish
- Order adjustable post kits and shelves separately

ITEM NO	SIZE	DESCRIPTION
PS18C	USE WITH 18"W SHELF	ADJUSTABLE SINGLE SHELF BRACKET
PS24C	USE WITH 24"W SHELF	ADJUSTABLE SINGLE SHELF BRACKET
DPS18C	USE WITH 18"W SHELF	ADJUSTABLE DOUBLE SHELF BRACKET
DPS24C	USE WITH 24"W SHELF	ADJUSTABLE DOUBLE SHELF BRACKET



WIRE WALL MOUNT SHELF

- Brackets come in single and double
- Chrome or silver epoxy finish
- Order shelf and bracket separately, variety of sizes available

ITEM NO	SIZE	DESCRIPTION
AB18C	USE WITH 18"W SHELF	SINGLE SHELF BRACKET CHROME
DAB18C	USE WITH 18"W SHELF	DOUBLE SHELF BRACKET CHROME
AB24EP	USE WITH 24"W SHELF	SINGLE SHELF BRACKET SILVER EPOXY
AB24EP	USE WITH 24"W SHELF	DOUBLE SHELF BRACKET SILVER EPOXY



PLATE CASTERS

- Compatible with wire shelving kits
- rubber, polyurethane or pneumatic
- Each contains (4) wheels, (2) swivel and (2) rigid or w/ brake

ITEM NO	SIZE	DESCRIPTION
CAP5BR	5" X 1-1/2"	RUBBER CASTERS W/ (2) BRAKES
CAP5RSP	5" X 1-1/2"	POLYURETHANE CASTERS W/ (2) RIGID
CAP6RSR	6" X 2"	RUBBER CASTERS W/ (2) RIGID
CAP8RSR	8" X 2"	RUBBER CASTERS W/ (2) RIGID
CAP8RN	8" X 2.8"	PNEUMATIC CASTERS W/ (2) RIGID



TRAY DRYING RACK

- Fits on 24"W shelves only
- Uprights spaced 1.75" apart
- Poly-Z-Brite finish

ITEM NO	SIZE	DESCRIPTION
TR1224Z	12"L X 24"W	TRAY DRYING RACK
TR1624Z	16"L X 24"W	TRAY DRYING RACK



TENNANT T300 FLOOR SCRUBBER

- Conventional and loaded models
- Walk-behind
- Includes battery and on board charger

ITEM NO	SIZE	DESCRIPTION
T300E-1001D	20" DISK	CONVENTIONAL SCRUBBER
T300E-2001D	20" DISK	CONVENTIONAL SELF PROPEL SCRUBBER
T300E-2002D	20" DISK	LOADED SCRUBBER W/ NANOCLEAN
T300E-500-O	20" DISK	CONVENTIONAL ORBITAL SELF PROPEL SCRUBBER
MV-T300E-0047	24" DISK	CONVENTIONAL SELF PROPEL SCRUBBER
MV-T300E-0008	24" DISK	LOADED SCRUBBER W/ NANOCLEAN



TENNANT T500 FLOOR SCRUBBER

- Conventional and loaded models
- Walk-behind
- Includes battery and on board charger

ITEM NO	SIZE	DESCRIPTION
T500E-1001D	26" DISK	CONVENTIONAL SCRUBBER
T500-3001D	26" DISK	LOADED SCRUBBER W/ NANOCLEAN
T500E-1002D	28" DISK	CONVENTIONAL SCRUBBER
T500-3002D	28" DISK	LOADED SCRUBBER W/ NANOCLEAN
T500E-1003D	32" DISK	CONVENTIONAL SCRUBBER
T500-3003D	32" DISK	LOADED SCRUBBER W/ NANOCLEAN



TENNANT T600 FLOOR SCRUBBER

- Conventional and loaded models
- Walk-behind
- Includes battery and on board charger

ITEM NO	SIZE	DESCRIPTION
T600E-1001D	32" DISK	CONVENTIONAL SCRUBBER W/240AH BATTERY
T600-3001D	32" DISK	LOADED SCRUBBER W/NANOCLEAN & 360AH BATTERY



TENNANT T391 FLOOR SCRUBBER

- Conventional scrubber
- Walk-behind
- Includes battery and on board charger

ITEM NO	SIZE	DESCRIPTION
T391-9022790	28" DISK	CONVENTIONAL SCRUBBER W/PAD DRIVER
T391-9022794	32" DISK	CONVENTIONAL SCRUBBER W/PAD DRIVER



TENNANT T390 FLOOR SCRUBBER

- Dual disk cleaning path
- Walk-behind
- Includes battery and on board charger

ITEM NO	SIZE	DESCRIPTION
T390-9022006	28" DISK	CONVENTIONAL SELF-PROPELLED SCRUBBER



TENNANT T290 FLOOR SCRUBBER

- Single disk cleaning path
- Walk-behind
- Includes battery and on board charger

ITEM NO	SIZE	DESCRIPTION
T290-9022000	20" DISK	PAD ASSIST & 130AH WET BATTERIES
T290-9022003	20" DISK	SELF-PROPEL & 130AH WET BATTERIES
9022001	20" DISK	PAD ASSIST & 150AH WET BATTERIES
9022004	20" DISK	SELF PROPEL & 150AH WET BATTERIES



TENNANT T260 FLOOR SCRUBBER

- Single disk cleaning path
- Walk-behind
- Includes battery and on board charger

ITEM NO	SIZE	DESCRIPTION
T260-TN8001004	20" DISK	PAD ASSIST & 135AH SEALED AGM BATTERIES



TENNANT T2 SMALL FLOOR SCRUBBER

- Conventional scrubber
- Walk-behind
- Includes battery and on board charger

ITEM NO	SIZE	DESCRIPTION
T2-1001D	17" DISK	CONVENTIONAL SCRUBBER W/105AH BATTERY



TENNANT MICRO SCRUBBER

- Cylindrical scrubber
- Walk-behind
- 15" Cleaning path

ITEM NO	RUN TIME	DESCRIPTION
9008638	60 MIN RUN TIME	LI-ION BATTERY POWERED
9004191	CONTINUOUS	CORDED POWER SOURCE



TENNANT CS5 MICRO SCRUBBER

- Movable handle & compact size
- Walk-behind
- Optional battery upgrade

ITEM NO	SIZE	DESCRIPTION
CS5-1251580	11" CLEANING PATH	LI-ION BATTERY



TENNANT CS16 MICRO SCRUBBER

- Ergonomic handle & motorized brush agitation
- Walk-behind
- Efficient water recovery

ITEM NO	SIZE	DESCRIPTION
CS16-LPTB03328	14" CLEANING PATH	CORDED OR BATTERY OPERATED OPTIONS



TENNANT FLOOR MACHINE

- Single speed
- Walk-behind
- For scrubbing, polishing & stripping

ITEM NO	SIZE	DESCRIPTION
FM-20-SS-9007336	20" HEAD SIZE	HEAVY-DUTY, POLYETHYLENE CORDED MACHINE



TENNANT T581 FLOOR SCRUBBER

- Single disk cleaning path
- Ride-On
- Includes battery and on board charger

ITEM NO	SIZE	DESCRIPTION
T581-9022008	20" DISK	LINATEX SQUEEGEE BLADES & 150AH WET BATTERIES



TENNANT T681 FLOOR SCRUBBER

- Dual disk cleaning path
- Ride-On
- Includes battery and on board charger

ITEM NO	SIZE	DESCRIPTION
T681-9052040	32" DISK	LINATEX SQUEEGEE BLADES & 240AH WET BATTERIES



TENNANT T7 FLOOR SCRUBBER

- Conventional scrubber
- Ride-On
- Includes battery and on board charger

ITEM NO	SIZE	DESCRIPTION
T7-1001D	26" DISK	240AH BATTERIES & EC-H2O NANOCLEAN OPTION



TENNANT T380 FLOOR SCRUBBER

- Robotic auto scrubber
- Ride-On option
- Hydrolink battery watering & off-board charger

ITEM NO	SIZE	DESCRIPTION
T380AMR-ECH20	20" DISK SCRUB HEAD	225AH LITHIUM ION BATTERIES & NANOCLEAN TECHNOLOGY
T380AMR-500-D	20" DISK SCRUB HEAD	225AH LEAD ACID BATTERIES & CONVENTIONAL CLEANING



TENNANT X4 ROVR AUTONOMOUS FLOOR SCRUBBER

- Robotic auto scrubber
- For stores with approx. 25k SF of cleaning area
- Includes lifetime autonomy

ITEM NO	SIZE	DESCRIPTION
X4ROVR-500-D	20" DUAL DISK SCRUBBING PATH	38"L X 22"W X 44"H; LITHIUM-ION 90AH BATTERY



TENNANT I-MOP XL

- Auto disk scrubber
- (2) Medium blue brushes and squeegee
- Includes battery and on board charger

ITEM NO	SIZE	DESCRIPTION
1231845	18.1" CLEANING PATH	I-MOP XL
9016402	18.1" CLEANING PATH	I-MOP XL W/ BACKUP BATTERY PACK



TENNANT I-MOP XXL

- Auto disk scrubber
- (2) Medium blue brushes and squeegee
- Includes battery and off board charger

ITEM NO	SIZE	DESCRIPTION
1264255	24.4" CLEANING PATH	I-MOP XXL & LITHIUM-ION BATTERY



TENNANT I-MOP LITE

- Auto disk scrubber
- Rotating twin brushes with splash guards
- Includes battery and off board charger

ITEM NO	SIZE	DESCRIPTION
1263271	14.5" CLEANING PATH	I-MOP LITE & LITHIUM-ION BATTERY
IMOPLITE-9022310	14.5" CLEANING PATH	I-MOP LITE W/BACKUP BATTERY PACK



TENNANT B5/B7 BURNISHER

- Walk behind battery powered
- Automated down pressure
- Includes battery and on board charger

ITEM NO	SIZE	DESCRIPTION
MV-B7-0008	27" DISK	WALK BEHIND BURNISHER
MV-B5-0010	20" DISK	WALK BEHIND BURNISHER



TENNANT BR-2000-DC BURNISHER

- Walk behind corded powered
- High-speed with dust control
- Includes 1 pad

ITEM NO	SIZE	DESCRIPTION
9007349	20"	2000RPM, FLEXIBLE PAD DRIVER



TENNANT V-LWU-13B UP-RIGHT VACUUM

- Light weight
- No-tool brush replacement
- Cleans a variety of floor surfaces quickly and easily

ITEM NO	SIZE	DESCRIPTION
1238914	13"L X 15"W	BATTERY POWERED VACUUM



TENNANT V-DMU-14 UP-RIGHT VACUUM

- Corded power supply
- No-tool maintenance
- HEPA filtration

ITEM NO	SIZE	DESCRIPTION
1060829	14" CLEANING PATH	SINGLE MOTOR
V-DMU-14-1068027	14" CLEANING PATH	DUAL MOTOR



TENNANT V-BP-6 BACK- PACK VACUUM

- Available in corded or battery powered
- Low noise levels and HEPA filtration
- Operates with a Deuter branded hiking harness

ITEM NO	SIZE	DESCRIPTION
9013473	9"L X 11"W	CORDED BACKPACK VACUUM
9017567	9"L X 11"W	BATTERY POWERED BACKPACK VACUUM



TENNANT V-WD WET/DRY VACUUM

- 40'L power cord
- Shock-proof tank
- HEPA filtration

ITEM NO	SIZE	DESCRIPTION
1245656	36"H X 36"W X 23"L	24 GAL. WET/DRY VAC.



TENNANT E5 CARPET EX- TRACTOR

- Low profile design for easy maneuvering
- Hygienic tanks
- Can adjust to different carpet depths w/ o tools

ITEM NO	SIZE	DESCRIPTION
9004194	27" L X 19" W X 28" H	15" CLEANING PATH CORDED CARPET EXTRACTOR



TENNANT EX-SC CARPET EXTRACTOR

- Deep cleaning, mid-size
- Dual spray nozzles & brush meter
- 50' power cord

ITEM NO	SIZE	DESCRIPTION
9007486	43" L X 20" W X 34" H	17" CLEANING PATH CORDED CARPET EXTRACTOR



BETCO BLOWER

- Dries carpet, hard floors, paint etc.
- Three blower speed settings
- 18.5' power cord

ITEM NO	SIZE	DESCRIPTION
9014819	18" L X 15" W X 18.2" H	1/2 HORSEPOWER, 120V CORDED BLOWER



BETCO GENIE B FLOOR SCRUBBER

- For daily scrubbing in tight places
- 14" pad assist disk
- Includes battery and on board charger

ITEM NO	SIZE	DESCRIPTION
E8303900	27" L X 17" W X 17" HS STORAGE/44" UPRIGHT	12 VOLT 75AH AGM BATTERY, UP TO 11,560 SF/HR



BETCO CREWMAN FLOOR SCRUBBER

- For areas less than 20,000 sq.ft.
- 20" pad assist disk
- Includes battery and on board charger

ITEM NO	SIZE	DESCRIPTION
E2996800	43" L X 38" H X 22" W W/O SQUEEGEE & 30" W W/SQUEEGEE	(2) 12V 115AH WET BATTERY
E2996900	43" L X 38" H X 22" W W/O SQUEEGEE & 30" W W/SQUEEGEE	(2) 12V 130AH WET BATTERY
E2996700	43" L X 38" H X 22" W W/O SQUEEGEE & 30" W W/SQUEEGEE	(2) 12V 110AH AGM BATTERY



BETCO GENESYS FLOOR SCRUBBER

- For areas less than 30,000 sq.ft.
- 20" pad assist disk
- Includes battery and on board charger

ITEM NO	SIZE	DESCRIPTION
E2670000	51" L X 42" H X 21" W W/O SQUEEGEE & 30" W W/SQUEEGEE	PAD ASSIST W/130AH WET BATTERY
E2670400	51" L X 42" H X 21" W W/O SQUEEGEE & 30" W W/SQUEEGEE	PAD ASSIST W/110AH AGM BATTERY
E2680000	51" L X 42" H X 21" W W/O SQUEEGEE & 30" W W/SQUEEGEE	SELF-PROPELLED W/130AH WET BATTERY
E2680800	51" L X 42" H X 21" W W/O SQUEEGEE & 30" W W/SQUEEGEE	SELF-PROPELLED W/150AH WET BATTERY
E2680400	51" L X 42" H X 21" W W/O SQUEEGEE & 30" W W/SQUEEGEE	SELF-PROPELLED W/110AH AGM BATTERY



BETCO ORBITAL FLOOR SCRUBBER

- For areas less than 30,000 sq.ft.
- 20" self-propelled orbital
- A cleaner & finish remover

ITEM NO	SIZE	DESCRIPTION
E2690000	46" L X 42" H X 21" W W/O SQUEEGEE & 30" W W/SQUEEGEE	SELF-PROPELLED W/130AH WET BATTERY
E2690800	46" L X 42" H X 21" W W/O SQUEEGEE & 30" W W/SQUEEGEE	SELF-PROPELLED W/150AH WET BATTERY
E2690400	46" L X 42" H X 21" W W/O SQUEEGEE & 30" W W/SQUEEGEE	SELF-PROPELLED W/110AH AGM BATTERY



BETCO SP FLOOR SCRUBBER

- For areas less than 100,000 sq.ft.
- Multiple size options
- Up to 4 hour run time

ITEM NO	SIZE	DESCRIPTION
E2720000	55" L X 44" H X 28" W W/O SQUEEGEE & 35" W W/SQUEEGEE	26" SELF PROPELLED DISK & (4) 6V 260AH WET BATTERY
E2721200	55" L X 44" H X 28" W W/O SQUEEGEE & 35" W W/SQUEEGEE	26" SELF PROPELLED DISK & (4) 6V 220AH AGM BATTERY
E2730000	56" L X 44" H X 30" W W/O SQUEEGEE & 40" W W/SQUEEGEE	28" SELF PROPELLED DISK & (4) 6V 260AH WET BATTERY
E2731200	56" L X 44" H X 30" W W/O SQUEEGEE & 40" W W/SQUEEGEE	28" SELF PROPELLED DISK & (4) 6V 220AH AGM BATTERY
E2750000	59" L X 44" H X 34" W/O SQUEEGEE & 45" W W/SQUEEGEE	32" SELF PROPELLED DISK & (4) 6V 260AH WET BATTERY
E2751200	59" L X 44" H X 34" W/O SQUEEGEE & 45" W W/SQUEEGEE	32" SELF PROPELLED DISK & (4) 6V 220AH AGM BATTERY



BETCO ORB FLOOR SCRUBBER

- For areas less than 100,000 sq.ft.
- 28" self-propelled orbital
- Up to 5.5 hour run time

ITEM NO	SIZE	DESCRIPTION
E2740000	54" L X 44" H X 29" W/O SQUEEGEE & 40" W W/SQUEEGEE	6V 260AH WET BATTERY, UP TO 31,500 SF/HR
E2745400	54" L X 44" H X 29" W/O SQUEEGEE & 40" W W/SQUEEGEE	6V 220AH AGM BATTERY, UP TO 31,500 SF/HR



BETCO LARGE RIDE-ON FLOOR SCRUBBER

- For areas less than 150,000 sq.ft.
- Multiple size options
- Automatic ride-on

ITEM NO	SIZE	DESCRIPTION
E2992600	59" L X 28" W X 52" H	26" RIDE ON W/(4) 6V 235AH WET BATTERY
E2992700	59" L X 28" W X 52" H	26" RIDE ON W/(4) 6V 200AH AGM BATTERY
E2993100	59" L X 34" W X 52" H	32" RIDE ON W/(4) 6V 235AH WET BATTERY
E2993200	59" L X 34" W X 52" H	32" RIDE ON W/(4) 6V 200AH AGM BATTERY



SINGLE PANEL TRAFFIC DOOR

- Fully gasketed insulated core
- Additional sizes available
- Constructed w/ rotationally molded polyethylene & STD windows

ITEM NO	SIZE	DESCRIPTION
R3684R	36"W X 84"H	SINGLE PANEL TRAFFIC DOOR
R3696R	36"W X 96"H	SINGLE PANEL TRAFFIC DOOR
R4284R	42"W X 84"H	SINGLE PANEL TRAFFIC DOOR
R4296R	32"W X 96"H	SINGLE PANEL TRAFFIC DOOR



DOUBLE PANEL TRAFFIC DOOR

- Fully gasketed insulated core
- Additional sizes available
- Constructed w/ rotationally molded polyethylene & STD windows

ITEM NO	SIZE	DESCRIPTION
R6084RD	60"W x 84"H	DOUBLE PANEL TRAFFIC DOOR
R6096RD	60"W X 96"H	DOUBLE PANEL TRAFFIC DOOR
R7284RD	72"W X 84"H	DOUBLE PANEL TRAFFIC DOOR
R7296RD	72"W X 96"H	DOUBLE PANEL TRAFFIC DOOR
R8484RD	84"W X 84"H	DOUBLE PANEL TRAFFIC DOOR
R8496RD	84"W X 96"H	DOUBLE PANEL TRAFFIC DOOR



CAFÉ DOORS

- Café style doors with posts
- Additional sizes available
- Constructed of a polymer cell core

ITEM NO	SIZE	DESCRIPTION
P11PGD4836	48"W x 36"H	SINGLE PANEL GATE DOOR
P11PGD3636	36"W X 36"H	SINGLE PANEL GATE DOOR



PVC STRIP CURTAIN

- Used for a wide range of applications
- Easy to install and maintain
- Available in many sizes to fit all openings

ITEM NO	SIZE	DESCRIPTION
8802-6890C	60"W X 84"h	8" STRIPS
8802-80108C	80"W x 108"H	8" STRIPS
6602-4290C	36"W x 84"H	6" STRIPS



STRUCTURAL TUBE FRAME

- 2" x 6" for industrial applications
- Additional sizes available
- Steel, powder epoxy finish in standard gray (other colors available)

ITEM NO	SIZE	DESCRIPTION
STF3684R	36"W X 84"H	STRUCTURAL TUBE FRAME
STF3696R	36"W X 96"H	STRUCTURAL TUBE FRAME
STF6084RD	60"W X 84"H	STRUCTURAL TUBE FRAME
STF6096RD	60"W X 96"H	STRUCTURAL TUBE FRAME
STF7284RD	72"W X 84"H	STRUCTURAL TUBE FRAME
STF8496RD	84"W X 96"H	STRUCTURAL TUBE FRAME



LORPO 2 AIR CURTAIN

- Customer facing commercial installations
- Mounting heights up to 8'
- Available in lengths from 25" - 144"

ITEM NO	SIZE	DESCRIPTION
LPV225-1EBC-OB	208V	ELECTRIC HEAT - BLACK
LPV225-1ECC-OB	230V	ELECTRIC HEAT - BLACK
LPV225-1UA-OB	115V	NON HEATED - BLACK
LPV225-1UD-OB	208-230V	NON HEATED - BLACK



STD2 AIR CURTAIN

- Features 1/2 horsepower motor
- Mounting heights up to 12'
- Available in lengths from 36" - 144"

ITEM NO	SIZE	DESCRIPTION
STD236-1EBB-OB	208V	ELECTRIC HEAT - BLACK
STD236-1ECB-OB	230V	ELECTRIC HEAT - BLACK
STD236-1EHH-OB	460V	ELECTRIC HEAT - BLACK
STD236-1UG-OB	208-230V	NON HEATED - BLACK
STD236-1UU-OB	220V	NON HEATED - BLACK



SANITATION AIR CURTAIN

- ETL Sanitation Certified
- Mounting heights up to 7'
- Available in lengths from 36" - 144"

ITEM NO	SIZE	DESCRIPTION
N236-1UA-OB	115V	BLACK OR TITANIUM SILVER
N236-1UD-OB	208-230V	BLACK OR TITANIUM SILVER
N236-1UU-OB	220V	BLACK OR TITANIUM SILVER



VERTICAL BALER

- Vertical downstroke hydraulic baler
- Additional sizes available
- Excellent for disposing of high volume cardboard and dry waste

ITEM NO	SIZE	DESCRIPTION
1800HD	61"L X 38"W X 138"H	VERTICLE BALER
2300HD	78"L X 41"W X 152"H	VERTICLE BALER
3400HD	78"L X 48"W X 152"H	VERTICLE BALER



COMPACTOR

- Self contained compactor
- Different feed options available
- Additional sizes available

ITEM NO	SIZE	DESCRIPTION
PT300	30 YARD CONTAINER	SELF CONTAINED COMPACTOR



AIR POWER LEVELER

- Advanced low pressure lifting system
- Simple push button operation
- Additional sizes and specs available

ITEM NO	SIZE	DESCRIPTION
ALG-987-SV-AIR	7'W X 8'L	AIR POWERED DOCK LEVELER
ALG-986-SV-AIR	6'W X 8'L	AIR POWERED DOCK LEVELER
ALG-988-SV-AIRE	8'W X 8'L	AIR POWERED DOCK LEVELER



HYDRAULIC LEVELER

- Operates on biodegradable fluid
- Minimum required maintenance
- Additional sizes and specs available

ITEM NO	SIZE	DESCRIPTION
RHH-4000	7'W X 8'L	STANDARD HYDRUALIC LEVLER
RHH-HCAP-4000	7'W X 8'L	HIGH CAPACITY HYDRAULIC LEVELER
RHV-4000	7'W X 8'L	VERTICAL STORING HYDRAULIC LEVELER



MECHANICAL LEVELER

- Pull chain operation
- Includes a yieldable lip
- Additional sizes and specs available

ITEM NO	SIZE	DESCRIPTION
RH78	7'W X 8'L	MECHANICAL DOCK LEVELER
RH68	6'W X 8'L	MECHANICAL DOCK LEVELER
RH88	8'W X 8'L	MECHANICAL DOCK LEVELER



SECTIONAL DOORS

- White insulated steel panels
- Motorized operation available
- Available in almost any size

ITEM NO	SIZE	DESCRIPTION
RHD-5224-6X7	6"W X 7"H OPENING	STEEL-RITE SECTIONAL DOOR
RHD-5224-6X8	6"W X 8"H OPENING	STEEL-RITE SECTIONAL DOOR
RHD-5224-8X8	8"W X 8"H OPENING	STEEL-RITE SECTIONAL DOOR



IMPACTABLE DOOR

- Constructed of impactable panel sections
- Ideal for high abusive environments
- Available in almost any size

ITEM NO	SIZE	DESCRIPTION
RFD-6X7	6"W X 7"H OPENING	RITE-FLEX IMPACTABLE DOOR
RFD-6X8	6"W X 8"H OPENING	RITE-FLEX IMPACTABLE DOOR
RFD-8X8	8"W X 8"H OPENING	RITE-FLEX IMPACTABLE DOOR

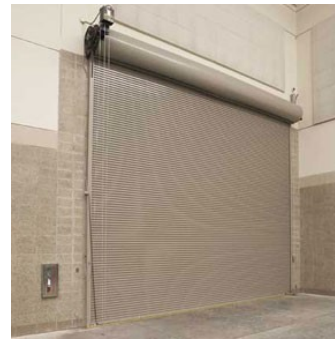

ROLLING STEEL DOOR

- Interlocking slats made of primed steel
- Motorized or manual operation
- Available in almost any size

ITEM NO	SIZE	DESCRIPTION
RSD-6X7	6"W X 7"H OPENING	ROLLING STEEL DOOR
RSD-6X8	6"W X 8"H OPENING	ROLLING STEEL DOOR
RSD-8X8	8"W X 8"H OPENING	ROLLING STEEL DOOR



DOCK SEAL

- Foam dock seal w/ fixed head pad
- Rugged armor plates
- Available in almost any size

ITEM NO	SIZE	DESCRIPTION
FDSP-SV-8X8	8"W X 8"H	WOOD BACKERS
TP901-NPSV-8X8-8	8"W X 8"H	TECHSTEEL BACKERS



DOCK LIGHT

- Cool head or HD-LED options
- Flexible spring arm design available
- Safety yellow powder coating

ITEM NO	SIZE	DESCRIPTION
RHF-SV-40	40" DUAL ARM	COOL HEAD DOCK LIGHT
RH-SV-60	60" DUAL ARM	COOL HEAD DOCK LIGHT
RH-SV-90	90" DUAL ARM	COOL HEAD DOCK LIGHT
SV-HD-LED-40	40" DUAL ARM	LED DOCK LIGHT



DOCK LEVELER

- Air powered or manual operation
- Additional sizes and specs available
- Gray enamel paint finish

ITEM NO	SIZE	DESCRIPTION
ALG-987-SV-AIR	7'W X 8'L	AIR POWERED DOCK LEVELER
ALG-986-SV-AIR	6'W X 8'L	AIR POWERED DOCK LEVELER
ALG-988-SV-AIRE	8'W X 8'L	AIR POWERED DOCK LEVELER



MOBILE LADDER

- Aluminum mobile platform ladder
- Slip resistant platform w/ a rail guard
- 300lb load capacity

ITEM NO	SIZE	DESCRIPTION
AP5006	6'H	MOBILE PLATFORM LADDER
AP5008	8'H	MOBILE PLATFORM LADDER
AP5010	10'H	MOBILE PLATFORM LADDER



STEP LADDER

- Aluminum step ladder
- Double-rivet step construction
- 300lb load capacity

ITEM NO	SIZE	DESCRIPTION
AS1012	12'H	STEP LADDER
AS1014	14'H	STEP LADDER
AS1016	16'H	STEP LADDER



ROLLING LADDER

- Fiberglass
- Non-conductive platform assembly
- Forward descent design, 300lb load capacity

Janitorial & Backroom Solutions

HUBERT® and UNFI are proud to partner together to offer a direct order smallwares program to independent retailers. We understand the challenges food retailers face, so this program offers an array of benefits, products, and services

Benefits & Services Include:

- Discounted Pricing
- Flat Rate Shipping
- Volume Discounting



Products You Need, When You Need Them

Hubert© consistently delivers fast, accurate and low-cost fulfillment services

- Over \$20M in inventory and 30,000 + items available from a single warehouse.
- Our private label, HUBERT© Brand, quality cost saving items.
- 94% of all orders ship same day, 98% within 24 hours.
- 95% of all orders ship from the HUBERT© warehouse in Ohio, reducing the number of shipments to help manage freight cost.



Project Management

Experienced team members on hand to assist with ordering & execution of smallwares standards

- Assistance developing standardized order guides
- Managing smallwares for new stores, remodels & resets
- Experts in visual merchandising
- Free consultation services

HOW TO ORDER:

- Visit our website at www.hubert.com or call 1-800-543-7374
- Legacy Supervalu retailers use account # 809240
- Legacy UNFI retailers use account # 233779
- For convenient invoicing: Legacy Supervalu retailers on your UNFI Retailer statement. Legacy UNFI retailers HUBERT© invoice or credit card

**Contact UNFI Equipment
Services for more information**



BETTER FOOD. BETTER FUTURE.

EQUIPMENT SERVICES

**11840 Valley View Road
Eden Prairie, MN 55344**